

FACTORY FURNITURE

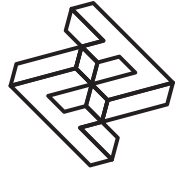

NORTH picnic table

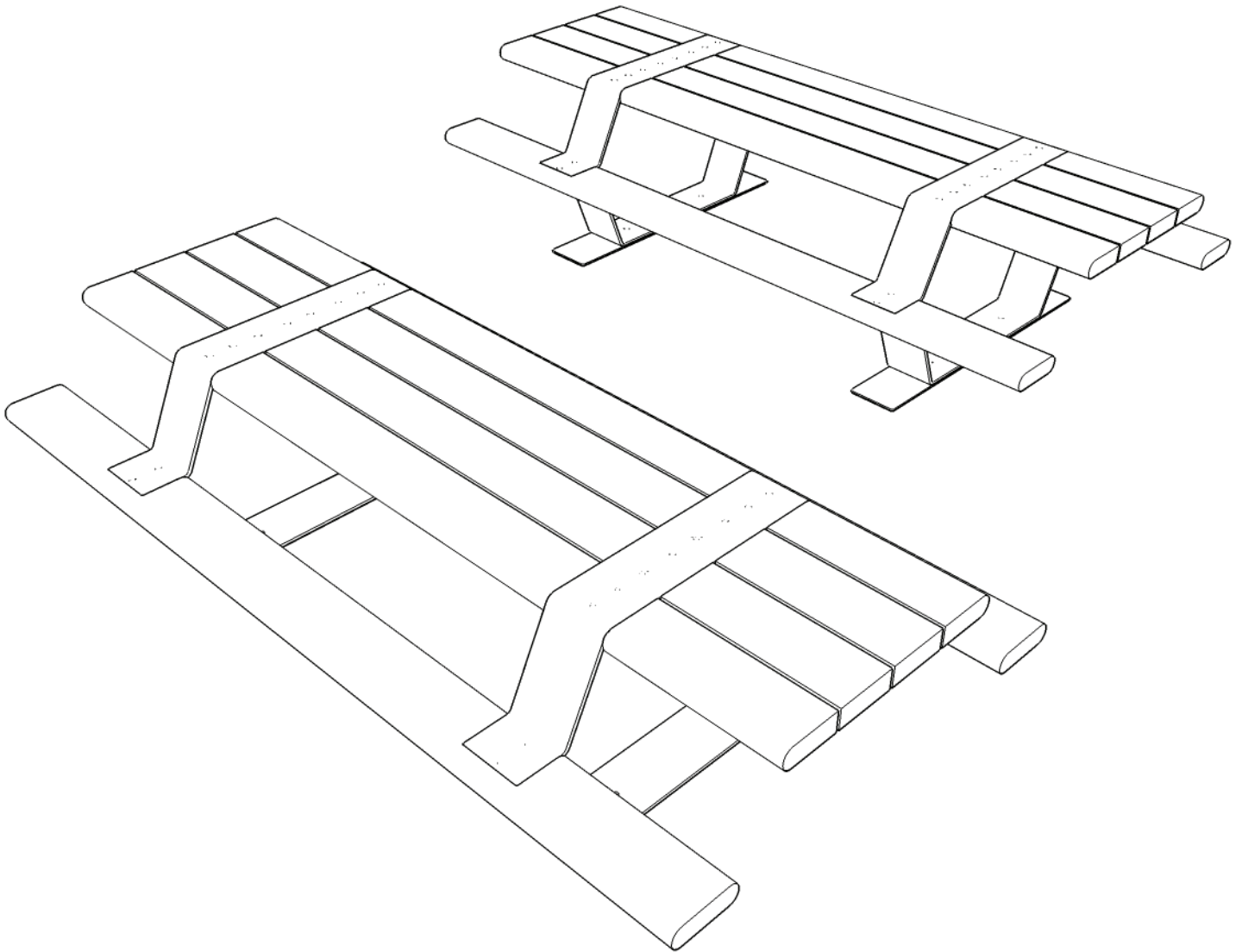

Operation & Maintenance Manual

Factory Furniture Ltd | 5 Pioneer Road | Faringdon | Oxfordshire SN7 7BU | T +44 (0)1367 242731
hello@factoryfurniture.co.uk | www.factoryfurniture.co.uk

We reserve the right to change specification without notice. © 2017 Factory Furniture Ltd

Introduction

Design

Design, shop drawings and development by Factory Furniture Ltd.

Manufacture

Factory Furniture manufactured components. Products are assembled in Factory workshops, checked and dispatched ready for installation. Replacement products or components thereof should be ordered direct from Factory Furniture Ltd.

Copyright

The design copyright for the product and drawing copyright remains the sole property of Factory Furniture Ltd.

General Specifications

NORTH Picnic Table (*Surface fix*)

Metric length 3000mm | width 1480mm | height 735mm

Imperial length 9' 10" | width 4' 10½" | height 2' 5"

Approx Weight 294kg

Fixing Centres 1680mm (5' 6") x 500mm (1' 7½")

NORTH Picnic Table (*Free-standing*)

Metric length 3000mm | width 1480mm | height 745mm

Imperial length 9' 10" | width 4' 10½" | height 2' 5½"

Approx Weight 325kg

Base Centres 1680mm (5' 6")

Detailed Material & Finish Specifications

Table & Seat Slats

- Manufactured from FSC® Siberian Larch (*other FSC timber options available incl. tanalised (pressure treated) softwood, tropical hardwood (e.g. Cumaru) or Shou Sugi Ban (charred)*)
- Slats are profiled and left untreated as standard.
- Fixed to galvanised mild steel frame.



Frame

- Manufactured from mild steel with a hot dip galvanised finish. Polyester powder coated finish available on request (*any RAL colour*)
- Upper and lower sections of frame bolted together with timber seat slats in between.
- Anchored to ground using 4 no. zinc-coated M10 x 75mm sleeve anchors per table.

General Maintenance (*Recommended Schedule & Guidelines*)

Daily/Weekly/Monthly (*or as adopted*)

Visual checks of timber table slats and frame - check all items for superficial or physical damage.

Three Monthly

Clean all items as detailed below check all fixings are seated correctly; inspect timber for serious damage and splinters.

Six Monthly

Secure all fixings; full clean as detailed below; check that table is firmly secured to the ground

Specific Maintenance Details

FSC Timber

Clean with a stiff brush once per year, especially in more exposed locations, in order to prevent a verdigris type build up on the timber surface. Ideally this should be completed in early spring. During the cleaning stage, all exposed timber surfaces should be inspected for splits and splinters. Any splinters and graffiti should be removed and the surface sanded with 100 grit sandpaper in order to remove any uneven / sharp edges or surfaces.

Galvanised & Polyester Powder Coated Surfaces

For general cleaning using a damp cloth and warm soapy water only. Scourers and abrasive cleaners are NOT suitable for this type of finish and may damage it. Before using any cleaning agents to remove graffiti etc. try on a small, inconspicuous area first to avoid causing more unsightly damage.

Repairs

FSC Timber

For light damage, please see section on specific maintenance details above. For instances of heavy damage, the timber item should be replaced. Please order against the part number reference in the reordering section towards the end of this manual.

Galvanised Surfaces

For light damage to hot dipped galvanised finishes repair using a high performance cold galvanising zinc spray (70% zinc or above). Spray application should be carried out in accordance with approved methods detailed by the product manufacturer. Please note that it is advisable to use professional painters to achieve best results when touching up larger areas.

Polyester Powder Coated Surfaces

For light damage (scratches, chips etc.) repair using touch-up paint to match original colour (available from Factory Furniture Ltd). Paint application should be carried out in accordance with approved methods detailed by the paint manufacturer. Please note that it is advisable to use professional painters to achieve best results when touching up larger areas. Products for respraying larger areas are available from Factory Furniture Ltd.

Heavy Damage

In the event of serious damage to any component, replacements should be ordered from Factory Furniture Ltd. In this event (or if the product needs to be disassembled for any reason), please contact Factory Furniture for detailed technical advice.

Contacts

Factory Furniture Ltd
5 Pioneer Road
Faringdon, Oxon
SN7 7BU UK

Tel +44 (0) 1367 242731

Email hello@factoryfurniture.co.uk

Web www.factoryfurniture.co.uk

Installation Instructions

ALL INSTALLATION WORKS TO BE CARRIED OUT BY COMPETENT PERSONNEL - INSTALL AS COMPLETE UNIT

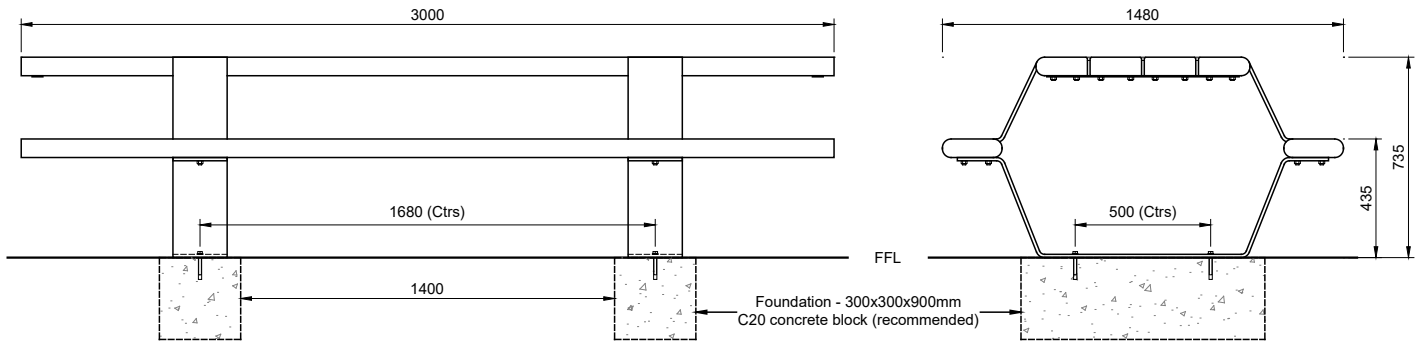

Table - Surface fix

North Picnic Table

1. Install suitable foundation pads (see illustration) each with top face at ground level.
2. Position table in correct orientation with bases centrally on foundation pads; mark hole positions through frame.
3. Remove the table; drill holes $\text{\O}12\text{mm}$ x 75mm deep (or as bolt manufacturer's recommendations).
4. Clear debris from holes.
5. Reposition table and fix to foundation pads using 4 no. zinc-coated M10 x 75mm sleeve anchors tightened to 50Nm (or as per manufacturer's instruction). Ensure table remains level during fixing process.

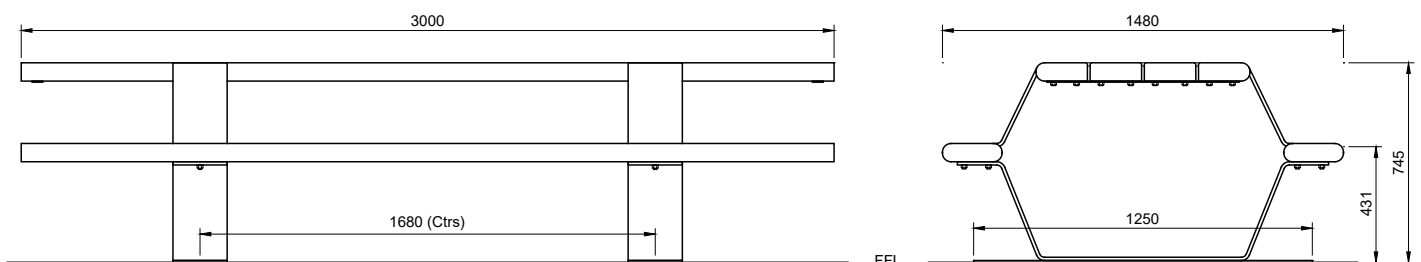
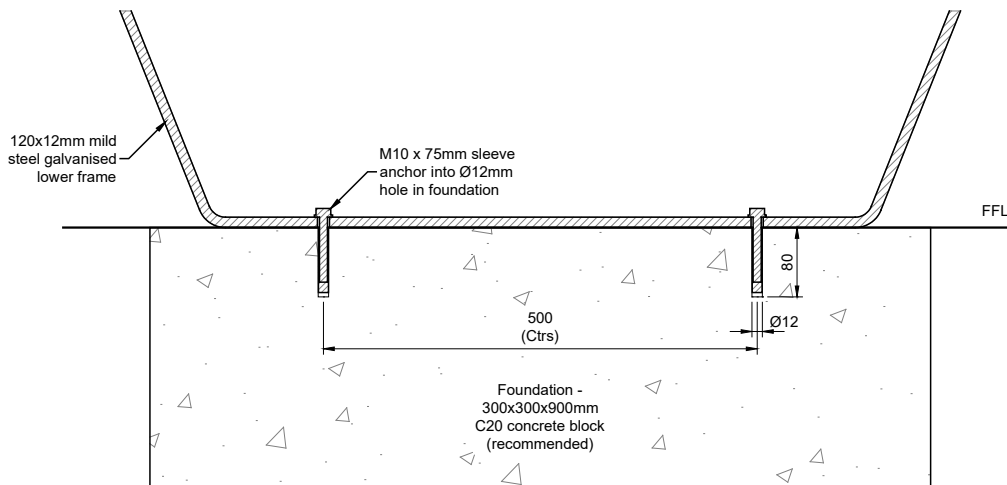

Table - Free-Standing Option