

FACTORY FURNITURE

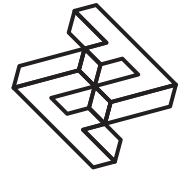

Concrete RAKT bench (0.9m)

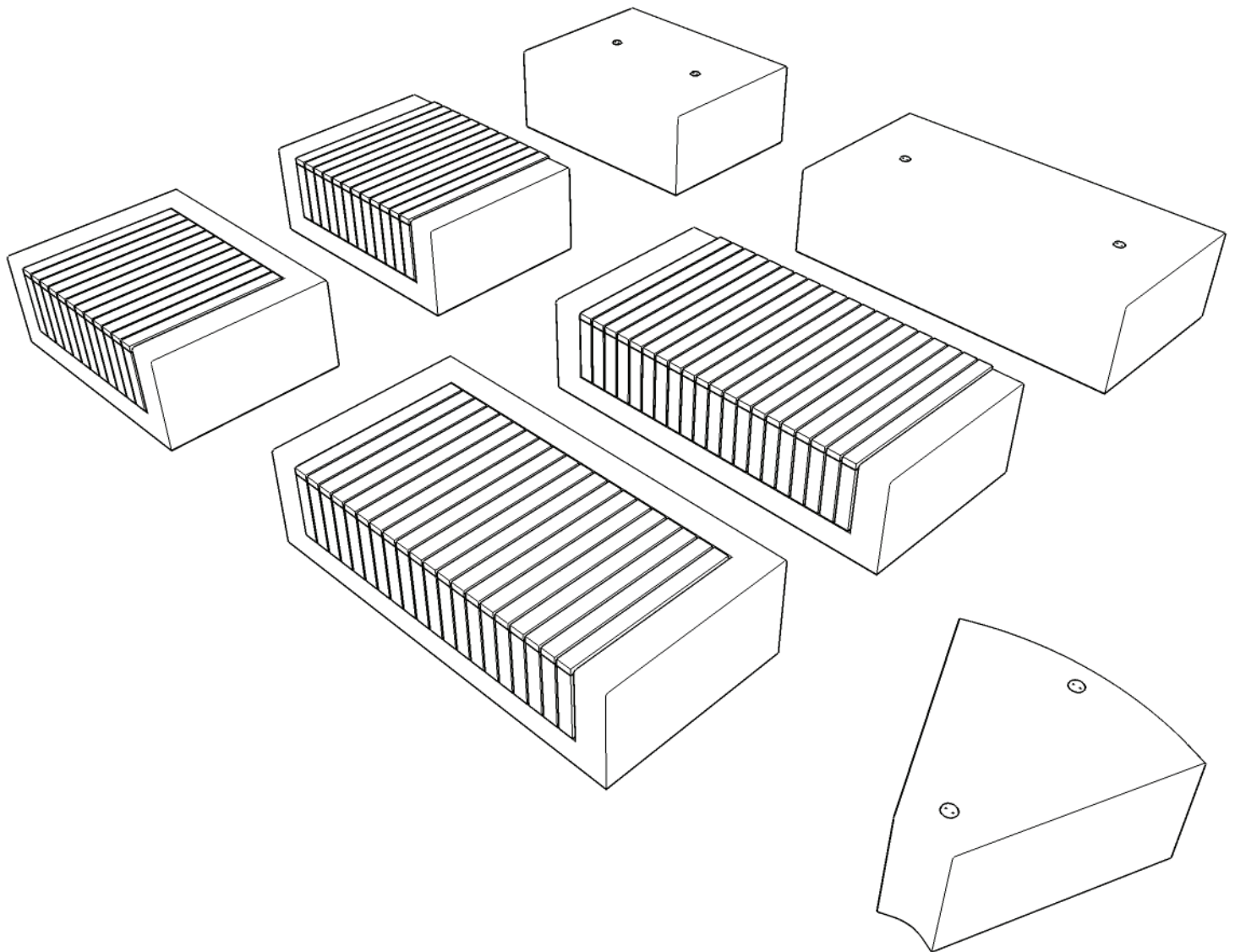

Operation & Maintenance Manual

Introduction

Design

Design, shop drawings and development by Factory Furniture Ltd.

Manufacture

Factory Furniture manufactured components. Products are assembled in Factory workshops, checked and dispatched ready for installation. Replacement products or components thereof should be ordered direct from Factory Furniture Ltd.

Copyright

The design copyright for the product and drawing copyright remains the sole property of Factory Furniture Ltd.

General Specifications

1.2x0.9m Single Bench

Metric L 1200mm | W 905mm | H 470mm

Imperial L 3' 11" | W 2' 11½" | H 1' 6½"

Approx Weight 1222kg

1.2x0.9m Double Bench

Metric L 1200mm | W 910mm | H 470mm

Imperial L 3' 11" | W 3' 0" | H 1' 6½"

Approx Weight 1210kg

1.2x0.9m Link Bench

Metric L 1200mm | W 900mm | H 465mm

Imperial L 3' 11" | W 2' 11½" | H 1' 6½"

Approx Weight 1256kg

0.9m Corner Bench

Metric L 665mm | W 630mm | H 465mm

Imperial L 2' 2" | W 2' 1" | H 1' 6½"

Approx Weight 598kg

1.8x0.9m Single Bench

Metric L 1800mm | W 905mm | H 470mm

Imperial L 5' 11" | W 2' 11½" | H 1' 6½"

Approx Weight 1828kg

1.8x0.9m Double Bench

Metric L 1800mm | W 910mm | H 470mm

Imperial L 5' 11" | W 3' 0" | H 1' 6½"

Approx Weight 1808kg

1.8x0.9m Link Bench

Metric L 1800mm | W 900mm | H 465mm

Imperial L 5' 11" | W 2' 11½" | H 1' 6½"

Approx Weight 1884kg

Detailed Material & Finish Specifications

Bench Slat Assembly

- Manufactured from FSC® certified tropical hardwood.
- Profiled and left untreated as standard (oil or microporous woodstain treatment available on request)
- Slats mounted onto mild steel frame - hot dipped galvanised and polyester powder coated finish (grey as standard or as per customer specification)



Base

- Manufactured from smooth white concrete. Surface is sealed to make it water repellent. Galvanised steel internal reinforcement.
- 2 no. lifting sockets included on top face beneath slat assembly (RD20 knuckle thread Din 405) **Lifting eyes not supplied**
- Bench slat assembly bolted to concrete base

General Maintenance *(Recommended Schedule & Guidelines)*

Daily/Weekly/Monthly *(or as adopted)*

Visual checks of bench slat assembly and concrete base - check all items for superficial or physical damage.

Three Monthly

Clean all items as detailed below check all fixings are seated correctly; inspect timber for serious damage and splinters.

Six Monthly

Secure all fixings; full clean as detailed below; ensure that bench slat assembly is securely fixed to concrete base.

Specific Maintenance Details

FSC Timber

Clean with a stiff brush once per year, especially in more exposed locations, in order to prevent a verdigris type build up on the timber surface. Ideally this should be completed in early spring. During the cleaning stage, all exposed timber surfaces should be inspected for splits and splinters. Any splinters and graffiti should be removed and the surface sanded with 100 grit sandpaper in order to remove any uneven / sharp edges or surfaces.

During the first few months after installation the tannin naturally occurring in the timber may leach out and cause a brown staining on the bases. This may be removed with a light solution of household bleach and water.

Polyester Powder Coated & Galvanised Surfaces

For general cleaning using a damp cloth and warm soapy water only. Scourers and abrasive cleaners are NOT suitable for this type of finish and may damage it. Before using any cleaning agents to remove graffiti etc. try on a small, inconspicuous area first to avoid causing more unsightly damage.

Granite / Concrete

Clean with a stiff brush once per year, especially in more exposed locations, in order to prevent a verdigris type build up on the surface. Ideally, this should be completed in early spring.

Repairs

FSC Timber

For light damage, please see section on specific maintenance details above. For instances of heavy damage, the timber item should be replaced. Please order against the part number reference in the reordering section towards the end of this manual.

Galvanised Surfaces

For light damage to hot dipped galvanised finishes repair using a high performance cold galvanising zinc spray (70% zinc or above). Spray application should be carried out in accordance with approved methods detailed by the product manufacturer. Please note that it is advisable to use professional painters to achieve best results when touching up larger areas.

Polyester Powder Coated Surfaces

For light damage (scratches, chips etc.) repair using touch-up paint to match original colour (available from Factory Furniture Ltd). Paint application should be carried out in accordance with approved methods detailed by the paint manufacturer. Please note that it is advisable to use professional painters to achieve best results when touching up larger areas. Products for respraying larger areas are available from Factory Furniture Ltd.

Heavy Damage

In the event of serious damage to any component, replacements should be ordered from Factory Furniture Ltd. Should further assistance be required (or if the product needs to be disassembled for any reason), please contact Factory Furniture for detailed technical advice.

Contacts

Factory Furniture Ltd
5 Pioneer Road
Faringdon, Oxon
SN7 7BU UK

Tel +44 (0) 1367 242731
Email hello@factoryfurniture.co.uk
Web www.factoryfurniture.co.uk

Installation Instructions

ALL INSTALLATION WORKS TO BE CARRIED OUT BY COMPETENT PERSONNEL - INSTALL AS COMPLETE UNIT

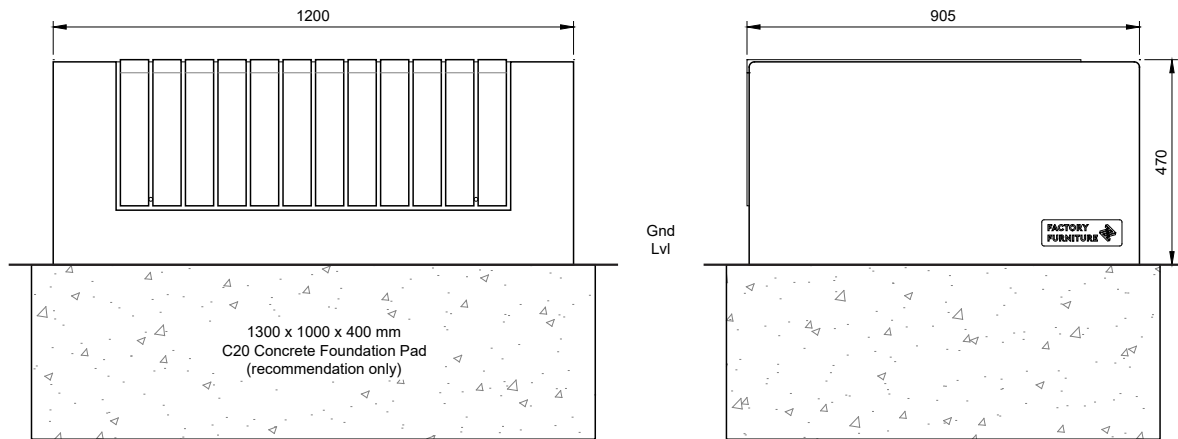

1.2 x 0.9m Single Bench (Detail same for Double & Link Bench)

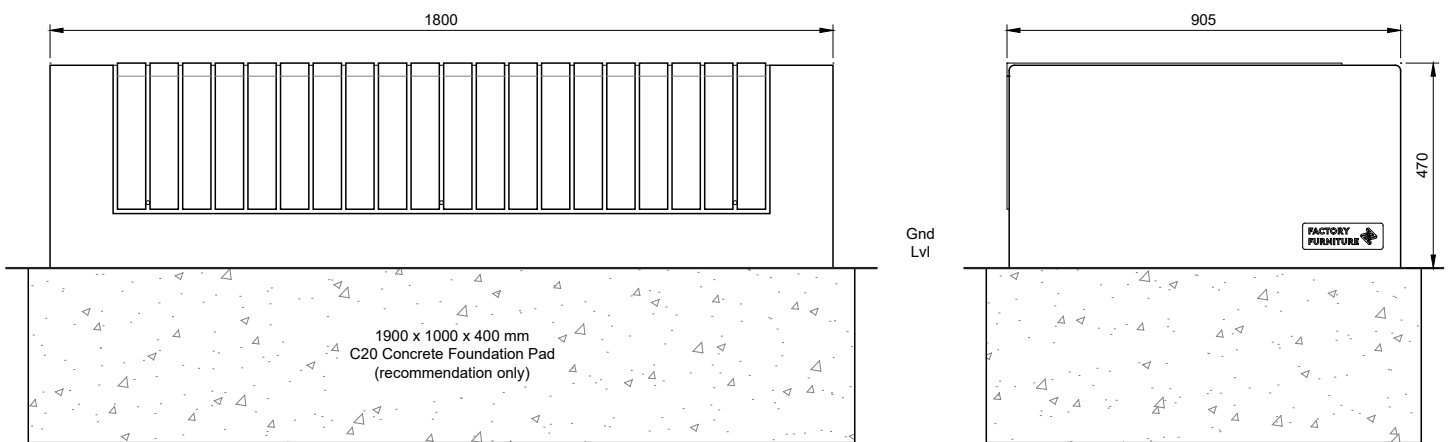

1.8 x 0.9m Single Bench (Detail same for Double & Link Bench)

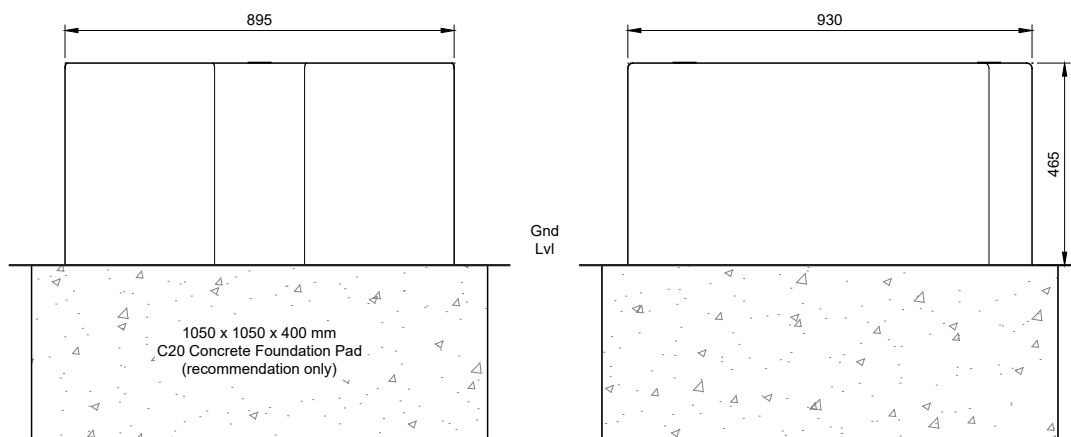

0.9m Corner Bench

Concrete Rakt Bench (0.9m)

1. Install suitable foundation pad (see illustration) with top face at ground level. Allow time for concrete to set (depends on size but minimum 48hrs and ideally at least 7 days).
2. Ensure that surface of pad is clear of debris, smooth and level as any lumps in the surface this may cause the bench to rock.
3. Using a crane or forklift - position bench base in correct orientation with base centrally on foundation pad. 2 no. integrated lifting sockets are provided for each bench section. ****Please note: Lifting eyes not supplied****
4. Screw on lifting socket dust covers (supplied) and re-attach bench slat assembly to concrete base using M8x30mm bolts provided. (Link and corner benches have no slat assembly).