

FACTORY FURNITURE

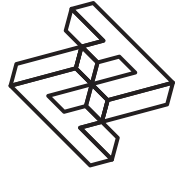

QUAY Bench, Seat & Stool

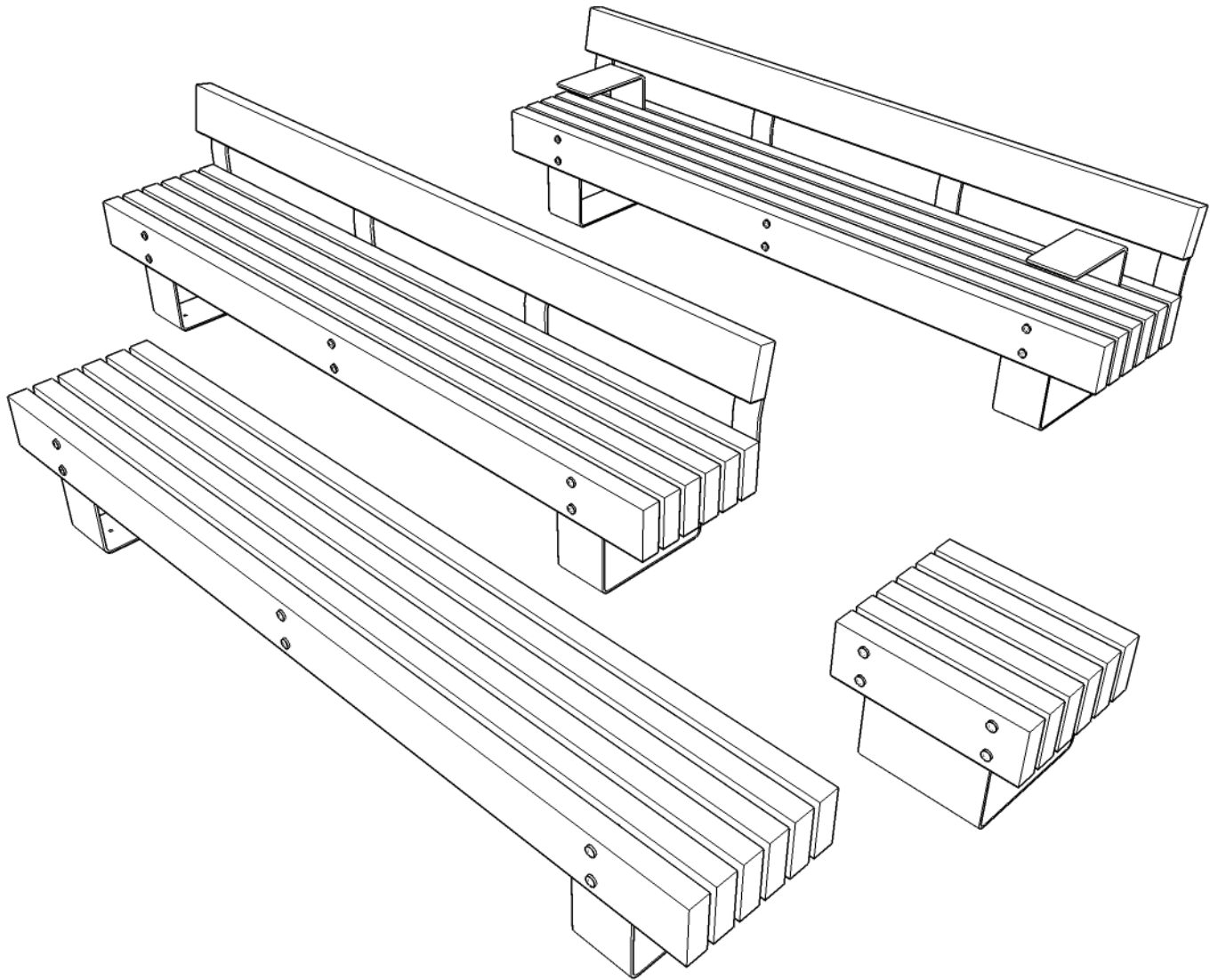

Operation & Maintenance Manual

Introduction

Design

Design, shop drawings and development by Factory Furniture Ltd.

Manufacture

Factory Furniture manufactured components. Products are assembled in Factory workshops, checked and dispatched ready for installation. Replacement products or components thereof should be ordered direct from Factory Furniture Ltd.

Copyright

The design copyright for the product and drawing copyright remains the sole property of Factory Furniture Ltd.

General Specifications

Bench

Metric length 3000mm | width 530mm | height 450mm

Imperial length 9' 10" | width 1' 9" | height 1' 5½"

Approx Weight 288kg (135kg for tanalised softwood version)

Fixing Centres 2400mm (7' 10½") x 300mm (12")

Seat (with back)

Metric length 3000mm | width 580mm | height 800mm

Imperial length 9' 10" | width 2' ½" | height 2' 7½"

Approx Weight 349kg (170kg for tanalised softwood version) - (376kg for armrest option)

Fixing Centres 2400mm (7' 10½") x 300mm (12")

Stool

Metric length 600mm | width 530mm | height 450mm

Imperial length 1' 11½" | width 1' 9" | height 1' 5½"

Approx Weight 86kg (55kg for tanalised softwood version)

Fixing Centres 250mm (10") x 300mm (12")

Detailed Material & Finish Specifications

Bench, Seat & Stool Slat Assembly

- Manufactured from FSC® certified tropical hardwood (*option for FSC tanalised softwood*)
- Slats are profiled and left untreated as standard (*oil or microporous woodstain treatment available on request except for tanalised option*).
- Spacers & end caps in aluminum (*stainless steel available on request*) concealing zinc-coated mild steel threaded tie rods tying slats together.
- Bench & seat supported on two bases attached to seat top. Stool supported on 1 base attached to stool top.



Backrest Assembly - Quay 'seat' only

- Slat manufactured from FSC® certified tropical hardwood (*option for FSC tanalised softwood available*).
- Slat is profiled and left untreated as standard (*oil or microporous woodstain treatment available on request except for tanalised option*)
- Backrest frame manufactured from mild steel with a hot dip galvanised finish.
- Backrest assembly bolted to seat slat assembly.
- Armrest (*available on request*) manufactured from mild steel with a hot dip galvanised finish. Bolted to seat.

Base Assembly

- Manufactured from mild steel with a hot dip galvanised finish. Bolted to slat assembly.
- Anchored to ground via 4 no. M10 x 130mm resin anchor studs and cap nuts per bench, seat or stool.

General Maintenance *(Recommended Schedule & Guidelines)*

Daily/Weekly/Monthly *(or as adopted)*

Visual checks of slats and frame - check all items for superficial or physical damage.

Three Monthly

Clean all items as detailed below check all fixings are seated correctly; inspect timber for serious damage and splinters.

Six Monthly

Secure all fixings; full clean as detailed below; check that bench / seat / stool is firmly secured in the ground

Specific Maintenance Details

FSC Timber

Clean with a stiff brush once per year, especially in more exposed locations, in order to prevent a verdigris type build up on the timber surface. Ideally this should be completed in early spring. During the cleaning stage, all exposed timber surfaces should be inspected for splits and splinters. Any splinters and graffiti should be removed and the surface sanded with 100 grit sandpaper in order to remove any uneven / sharp edges or surfaces.

During the first few months after installation the tannin naturally occurring in the timber may leach out and cause a brown staining on the bases. This may be removed with a light solution of household bleach and water.

Galvanised & Polyester Powder Coated

For general cleaning using a damp cloth and warm soapy water only. Scourers and abrasive cleaners are NOT suitable for this type of finish and may damage it. Before using any cleaning agents to remove graffiti etc. try on a small, inconspicuous area first to avoid causing more unsightly damage.

Repairs

FSC Timber

For light damage, please see section on specific maintenance details above. For instances of heavy damage, the timber item should be replaced. Please order against the part number reference in the reordering section towards the end of this manual.

Galvanised Surfaces

For light damage to hot dipped galvanised finishes repair using a high performance cold galvanising zinc spray (70% zinc or above). Spray application should be carried out in accordance with approved methods detailed by the product manufacturer. Please note that it is advisable to use professional painters to achieve best results when touching up larger areas.

Polyester Powder Coated Surfaces

For light damage (scratches, chips etc.) repair using touch-up paint to match original colour (available from Factory Furniture Ltd). Paint application should be carried out in accordance with approved methods detailed by the paint manufacturer. Please note that it is advisable to use professional painters to achieve best results when touching up larger areas. Products for respraying larger areas are available from Factory Furniture Ltd.

Heavy Damage

In the event of serious damage to any component, replacements should be ordered from Factory Furniture Ltd. Should further assistance be required (or if the product needs to be disassembled for any reason), please contact Factory Furniture for detailed technical advice.

Contacts

Factory Furniture Ltd
5 Pioneer Road
Faringdon, Oxon
SN7 7BU UK

Tel +44 (0) 1367 242731

Email hello@factoryfurniture.co.uk

Web www.factoryfurniture.co.uk

Installation Instructions

ALL INSTALLATION WORKS TO BE CARRIED OUT BY COMPETENT PERSONNEL - INSTALL AS COMPLETE UNIT

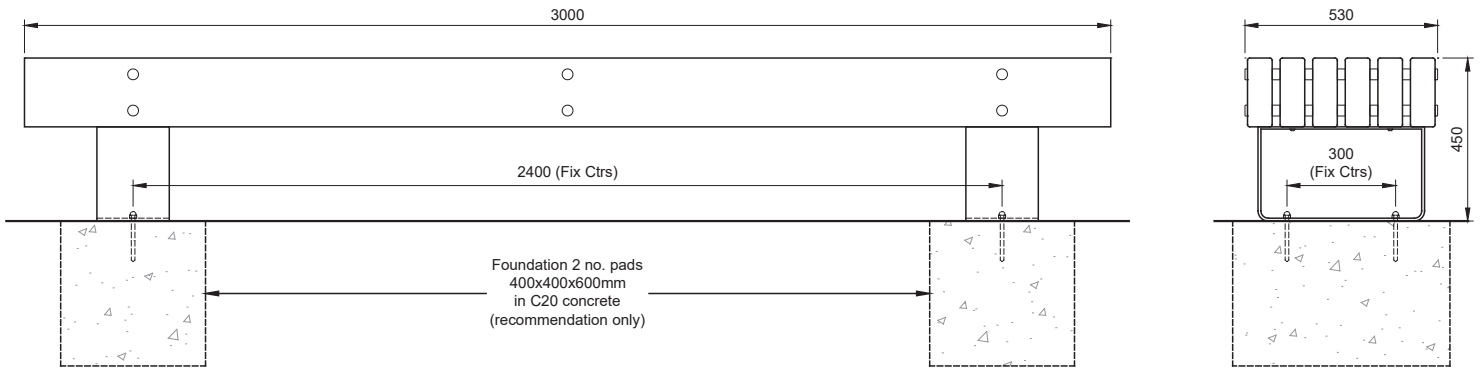

Bench (Same for Seat)

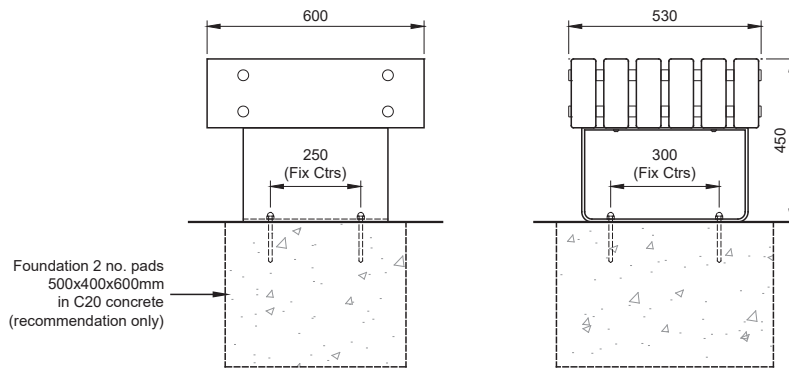

Stool

Quay Bench, Seat & Stool

1. Install suitable foundation pads (see illustrations) each with top face at ground level
2. Position bench / seat / stool in correct orientation with bases centrally on foundation pad(s); then mark hole positions through bases.
3. Remove bench / seat / stool; drill holes $\text{\O}12\text{mm}$ x 125mm deep (or as manufacturer's recommendations).
4. Clear debris from holes.
5. Fill the holes to within approximately 35mm from the top with Hilti HY150 resin (or similar). Lift the bench / seat / stool (with resin anchors / capnuts in place) and carefully lower the anchors into the holes, leave for two hours before proceeding.
6. Using a torque wrench, tighten nuts and washers over flange plates to 30Nm to fasten down the bench / seat / stool.
7. Check levels.

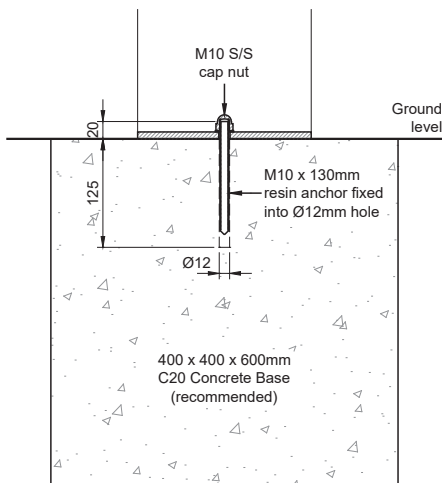

X-Section Thro' Base
(Bench and Seat)

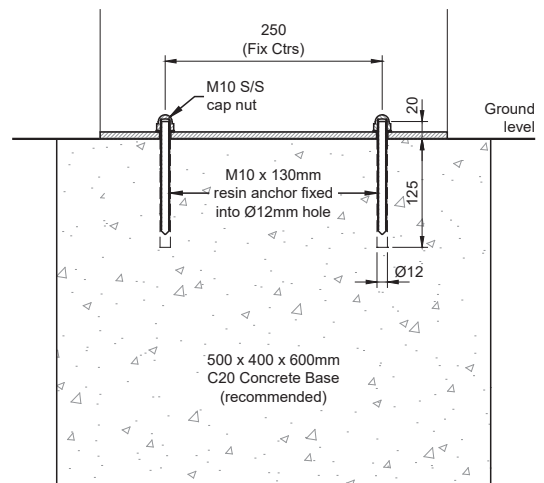

X-Section Thro' Base
(Stool)