

FACTORY FURNITURE

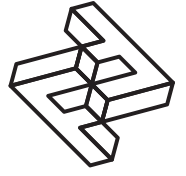

SINU bench (90°, 72° & straight)

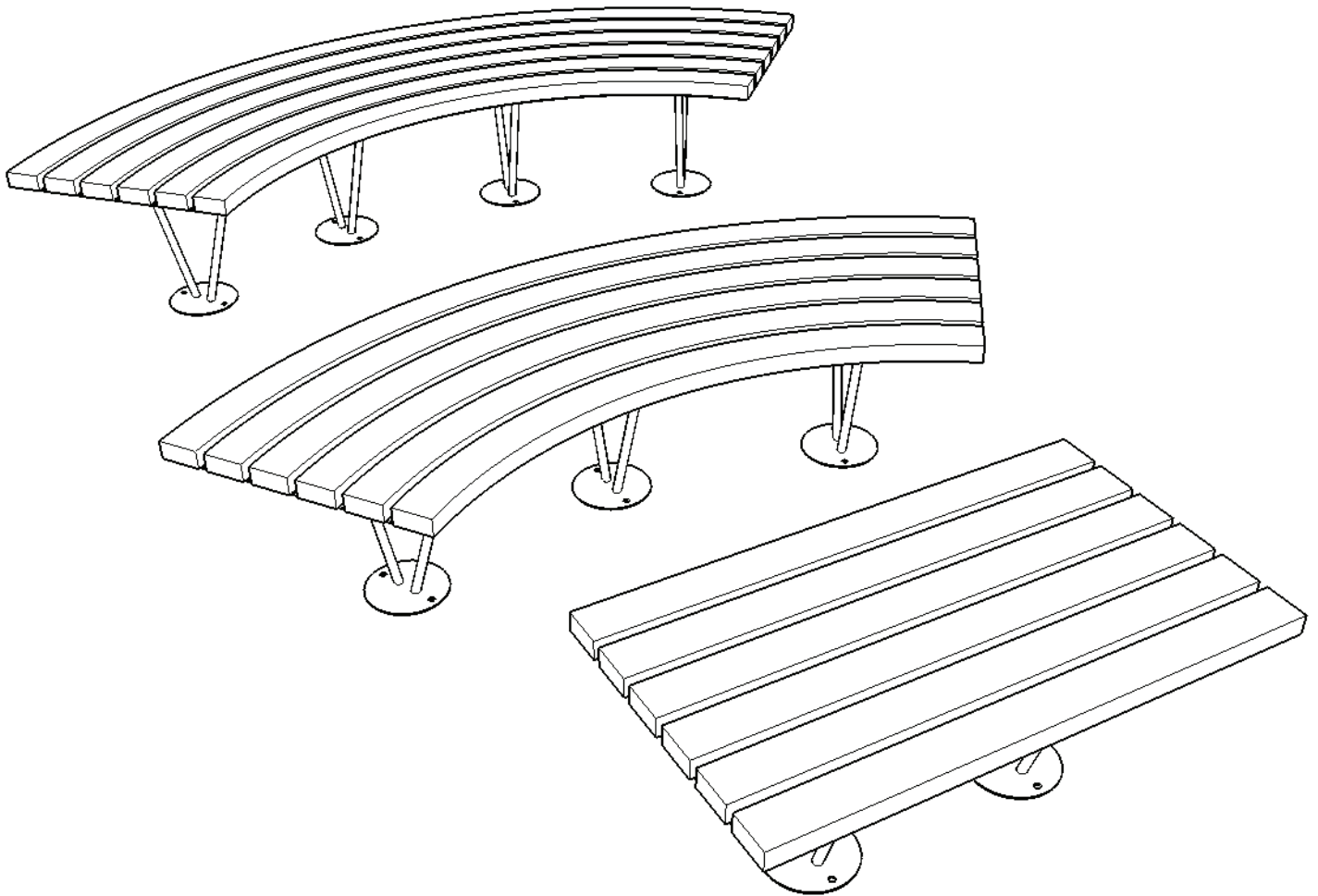

Operation & Maintenance Manual

Factory Furniture Ltd | 5 Pioneer Road | Faringdon | Oxfordshire SN7 7BU | T +44 (0)1367 242731
hello@factoryfurniture.co.uk | www.factoryfurniture.co.uk

We reserve the right to change specification without notice. © 2017 Factory Furniture Ltd

Introduction

Design

Design, shop drawings and development by Factory Furniture Ltd.

Manufacture

Factory Furniture manufactured components. Products are assembled in Factory workshops, checked and dispatched ready for installation. Replacement products or components thereof should be ordered direct from Factory Furniture Ltd.

Copyright

The design copyright for the product and drawing copyright remains the sole property of Factory Furniture Ltd.

General Specifications

90° Bench

Metric length 2335mm | width 910mm | height 450mm

Imperial length 7' 8" | width 2' 12" | height 1' 5½"

Approx Weight 93kg

Fixing Centres 1500mm (4' 11") x 200mm (8")

72° Bench

Metric length 1940mm | width 800mm | height 450mm

Imperial length 6' 4½" | width 2' 7½" | height 1' 5½"

Approx Weight 74kg

Fixing Centres 1100mm (3' 7½") x 115mm (4½")

Straight Bench

Metric length 1050mm | width 600mm | height 450mm

Imperial length 3' 5½" | width 1' 11½" | height 1' 5½"

Approx Weight 46kg

Fixing Centres 450mm (1' 5½") x 140mm (5½")

Detailed Material & Finish Specifications

Seat Slats & Sub-frame

- Manufactured from FSC® certified tropical hardwood (*other FSC timber options available upon request*)
- Profiled and left untreated as standard (*oil or microporous woodstain treatment available on request*)
- Slats mounted onto galvanised mild steel slat fix plate
- Fixed to 2-4 bases (depending on bench type)



Bases

- Manufactured from stainless steel - satin polished or polyester powder coated finishes (*powder coat colour grey as standard or to customer specification*)
- Anchored using 2 no. resin fixed M10 x 130mm threaded rods and cap nuts per base (*standard surface fix*). 90° bench - 4 bases, 72° bench - 3 bases, straight bench - 2 bases

General Maintenance *(Recommended Schedule & Guidelines)*

Daily/Weekly/Monthly *(or as adopted)*

Visual checks of seat top, back and bases - check all items for superficial or physical damage.

Three Monthly

Clean all items as detailed below check all fixings are seated correctly; inspect timber for serious damage and splinters.

Six Monthly

Secure all fixings; full clean as detailed below; check that seat/bench is firmly secured to the ground

Specific Maintenance Details

FSC Timber

Clean with a stiff brush once per year, especially in more exposed locations, in order to prevent a verdigris type build up on the timber surface. Ideally this should be completed in early spring. During the cleaning stage, all exposed timber surfaces should be inspected for splits and splinters. Any splinters and graffiti should be removed and the surface sanded with 100 grit sandpaper in order to remove any uneven / sharp edges or surfaces.

During the first few months after installation the tannin naturally occurring in the timber may leach out and cause a brown staining on the bases. This may be removed with a light solution of household bleach and water.

Stainless Steel *(polished stainless steel only)*

Clean as required, but at least every three months, using a stainless steel polish and a lint free cloth. To remove ground in dirt, a stainless steel finishing pad may be required.

Polyester Powder Coated & Galvanised

For general cleaning using a damp cloth and warm soapy water only. Scourers and abrasive cleaners are NOT suitable for these types of finish and may damage them. Before using any cleaning agents to remove graffiti etc. try on a small, inconspicuous area first to avoid causing more unsightly damage.

Repairs

FSC Timber

For light damage, please see section on specific maintenance details above. For instances of heavy damage, the timber item should be replaced. Please order against the part number reference in the reordering section towards the end of this manual.

Stainless Steel

Light damage (surface scratches etc.) can be removed using an emery pad (240 grit) and freeing oil such as 'WD40'. Care should be taken to follow the direction of the brushing grain. It is recommended that a trial repair be carried out on an unimportant surface first. No corrosive cleaners or other abrasives should be used. Any contamination, particularly carbon steel scuffs from vehicles, should be quickly removed to avoid corrosion.

Polyester Powder Coated Surfaces

For light damage (scratches, chips etc.) repair using touch-up paint to match original colour (available from Factory Furniture Ltd). Paint application should be carried out in accordance with approved methods detailed by the paint manufacturer. Please note that it is advisable to use professional painters to achieve best results when touching up larger areas. Products for respraying larger areas are available from Factory Furniture Ltd.

Galvanised Surfaces

For light damage to hot dipped galvanised finishes repair using a high performance cold galvanising zinc spray (70% zinc or above). Spray application should be carried out in accordance with approved methods detailed by the product manufacturer. Please note that it is advisable to use professional painters to achieve best results when touching up larger areas.

Heavy Damage

In the event of serious damage to any component, replacements should be ordered from Factory Furniture Ltd. In this event (or if the product needs to be disassembled for any reason), please contact Factory Furniture for detailed technical advice.

Reordering / Spares

Part No.	Item Description
P1010 / 01	1 no. Sinu 90° bench slat set (18 slats in total)
P1010 / 02	1 no. Sinu 72° bench slat set (18 slats in total)
P1010 / 03	1 no. Sinu Straight bench slat set (6 slats in total)
P1010 / 04	1 no. Sinu satin polished stainless steel base
P1010 / 05	1 no. Sinu 'module combiner' pack (brackets & fittings for combining two bench modules)

Instructions For Reordering

If possible, please specify job name or number at the time of reordering to enable identification of details such as the original species of timber used, stainless steel finishes and polyester powder coat colours etc. In any event where either, additional orders are required, or spares and replacements are required please contact Factory Furniture Ltd. Using the part numbers given above as reference should help us to process your enquiry more efficiently.

Note - All fittings required to assemble ordered parts will automatically be included in the order.

AutoCAD Drawing List

FF1010 / 01	SINU BENCH GENERAL ARRANGEMENT DRAWING
FF1010 / 02	SINU BENCH X-SECTION DRAWINGS
FF1010 / 03	SINU BENCH FSC TIMBER PARTS DRAWING
FF1010 / 04	SINU BENCH STEEL PARTS DRAWING
FF1010 / 05	SINU BENCH BASE ASSEMBLY FABRICATION DRAWING
FF1010 / 06	SINU BENCH SETTING OUT DRAWING
FF1010 / 07	SINU BENCH COMBINATION OPTIONS DRAWING
FF1010 / 08	SINU BENCH TEMPLATE DRAWING DRAWING

Contacts

Factory Furniture Ltd
5 Pioneer Road
Faringdon, Oxon
SN7 7BU UK

Tel +44 (0) 1367 242731
Email hello@factoryfurniture.co.uk
Web www.factoryfurniture.co.uk

Installation Instructions

ALL INSTALLATION WORKS TO BE CARRIED OUT BY COMPETENT PERSONNEL - INSTALL AS COMPLETE UNIT

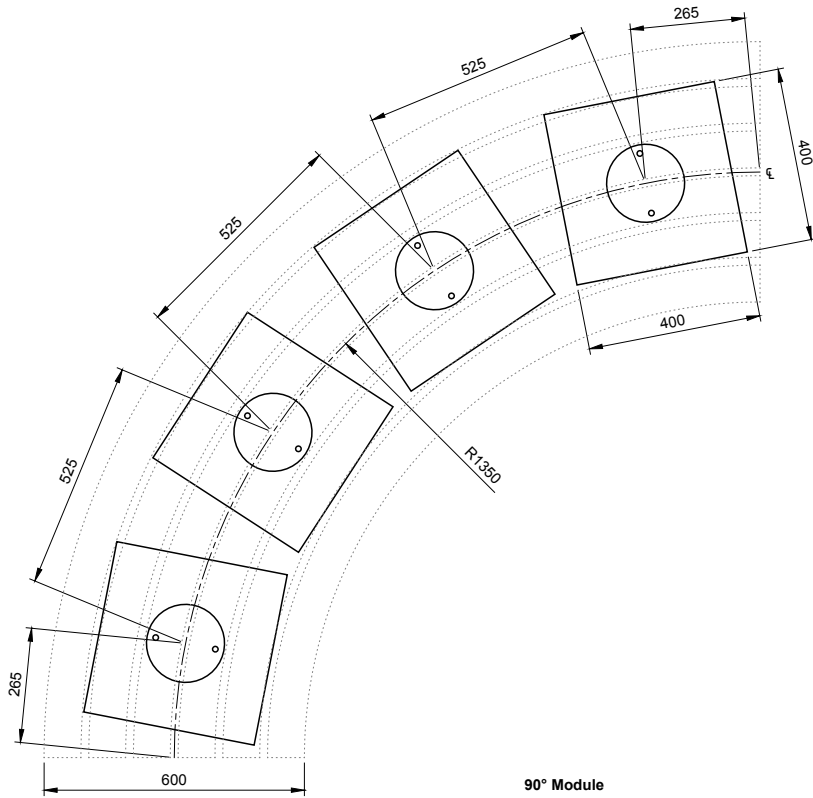

90° Module

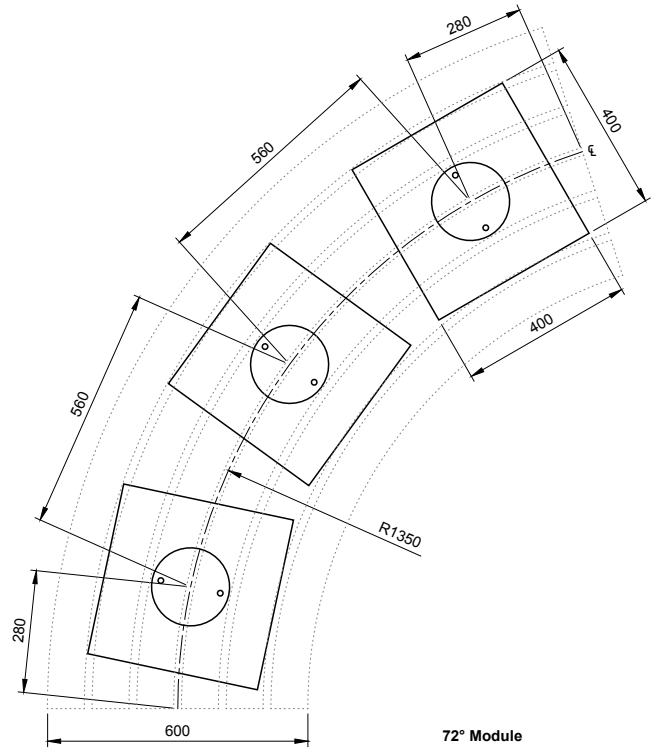

72° Module

Sinu Bench

1. Install suitable foundation pads (see illustration) each with top face at ground level.
2. Position bench in correct orientation with bases centrally on foundation pads. Mark hole positions through base plates. If multiple benches are being connected, fix benches together (see below) prior to marking base positions to guarantee alignment.
3. Remove the bench; drill holes $\text{Ø}14\text{mm} \times 130\text{mm}$ deep
4. Clear debris from holes.
5. Fill the holes to within approximately 35mm from the top with Hilti HY150 resin (or similar). Lift the bench (with threaded anchor rods / capnuts in place) and carefully lower the anchors into the holes, leave for two hours to cure before continuing.
6. Using a torque wrench, tighten nuts and washers over base plates to 30Nm to fasten down the bench.
7. Check level.

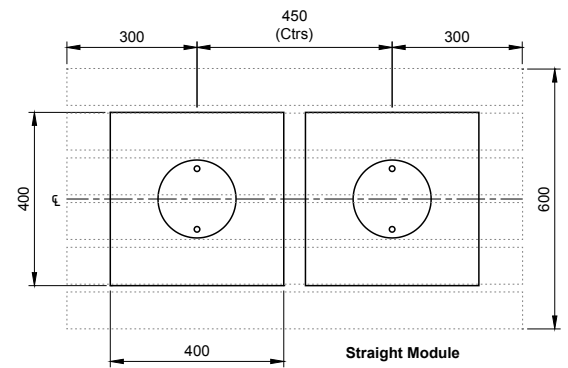

Straight Module

IMPORTANT NOTE:

Ensure that stainless steel is protected during site cutting of stone – contamination from disc cutters will produce corrosion on stainless steel components.

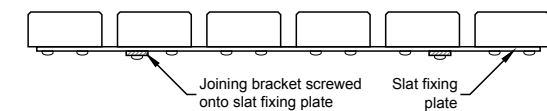
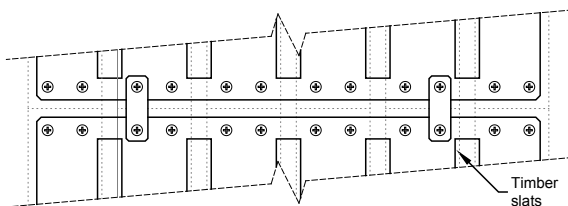

Sinu (Connecting bench modules together)

1. Fasten bench modules together using a pair of joining brackets per join. Fix each bracket using 2 no. No.14 x 32mm pan head pozi screws

