

FACTORY FURNITURE

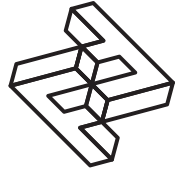

TORD bench & seat

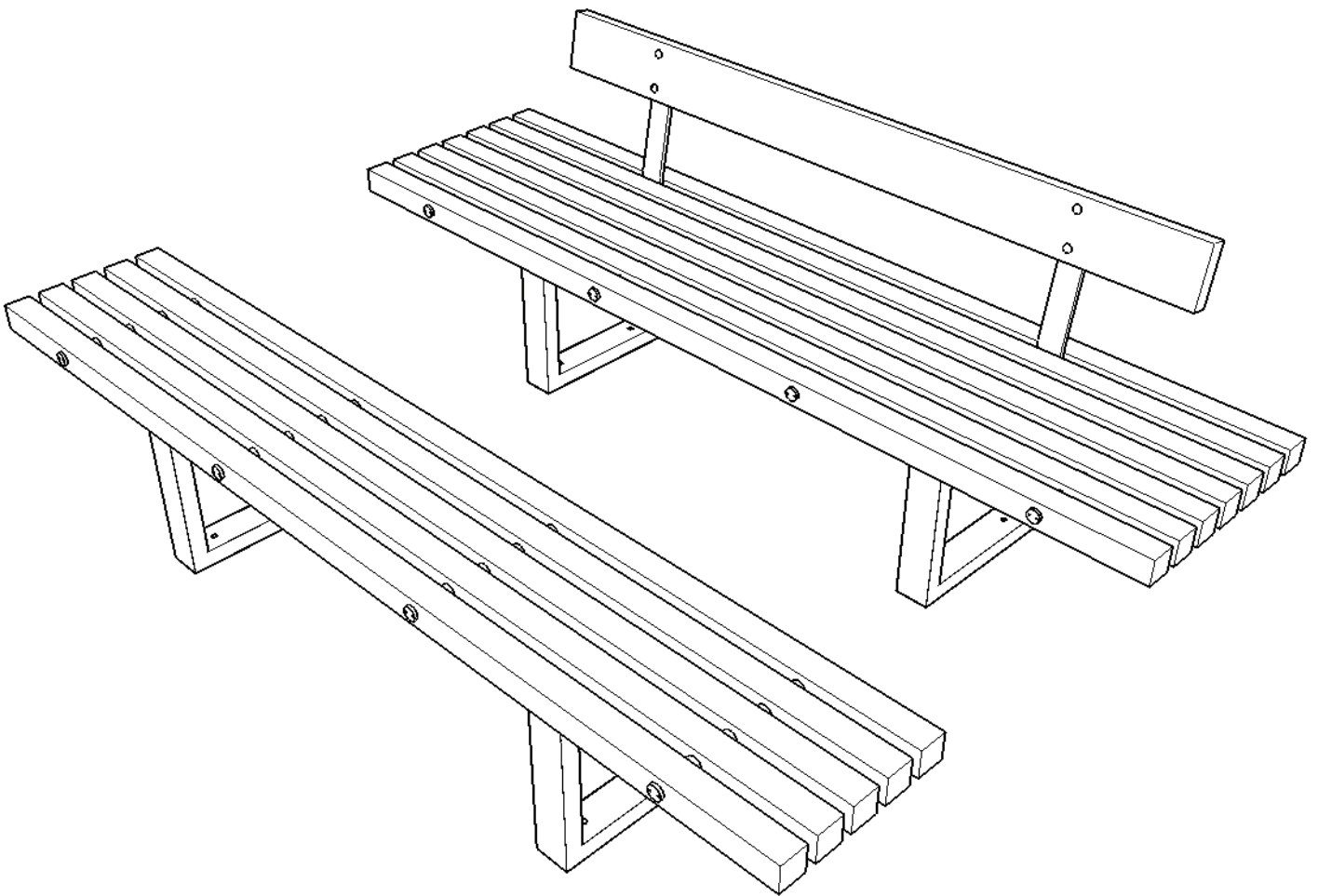

Operation & Maintenance Manual

Factory Furniture Ltd | 5 Pioneer Road | Faringdon | Oxfordshire SN7 7BU | T +44 (0)1367 242731
hello@factoryfurniture.co.uk | www.factoryfurniture.co.uk

We reserve the right to change specification without notice. © 2017 Factory Furniture Ltd

Introduction

Design

Design, shop drawings and development by Factory Furniture Ltd.

Manufacture

Factory Furniture manufactured components. Products are assembled in Factory workshops, checked and dispatched ready for installation. Replacement products or components thereof should be ordered direct from Factory Furniture Ltd.

Copyright

The design copyright for the product and drawing copyright remains the sole property of Factory Furniture Ltd.

General Specifications

Bench

Metric length 2300mm | width 400mm | height 450mm

Imperial length 7' 6½" | width 1' 3½" | height 1' 5½"

Approx Weight 59kg

Fixing Centres 1200mm (3' 11") x 160mm (6½")

Seat (with back)

Metric length 2300mm | width 565mm | height 800mm

Imperial length 7' 6½" | width 1' 10" | height 2' 7½"

Approx Weight 97kg

Fixing Centres 1200mm (3' 11") x 250mm (10")

Detailed Material & Finish Specifications

Seat Slats

- Manufactured from FSC® certified tropical hardwood
- Slats are profiled and left untreated as standard (oil or microporous woodstain treatment available on request)
- Spacers and end caps in aluminum (stainless steel available on request) fastening 4 no. zinc-coated mild steel threaded tie rods per seat top



Backrest Assembly - Tord 'seat' only

- Slat manufactured from FSC® certified tropical hardwood
- Slat is profiled and left untreated as standard (oil or microporous woodstain treatment available on request).
- Back support manufactured from stainless steel - satin polished finish (galvanised mild steel option available)
- Back rest assembly attached to seat via 4 no. fixing points

Base Assembly

- Manufactured from stainless steel RHS (all welded construction). Satin polished finish (galvanised mild steel option available on request)
- 2 off base assemblies per bench / seat attached to seat via 6 no. fixing points each
- Anchored via 2 no. M10 x 160mm resin anchor studs and cap nuts per base

General Maintenance *(Recommended Schedule & Guidelines)*

Daily/Weekly/Monthly *(or as adopted)*

Visual checks of bench/seat top, back and bases - check all items for superficial or physical damage.

Three Monthly

Clean all items as detailed below check all fixings are seated correctly; inspect timber for serious damage and splinters.

Six Monthly

Secure all fixings; full clean as detailed below; check that bench/seat is firmly secured to the ground

Specific Maintenance Details

FSC Timber

Clean with a stiff brush once per year, especially in more exposed locations, in order to prevent a verdigris type build up on the timber surface. Ideally this should be completed in early spring. During the cleaning stage, all exposed timber surfaces should be inspected for splits and splinters. Any splinters and graffiti should be removed and the surface sanded with 100 grit sandpaper in order to remove any uneven / sharp edges or surfaces.

During the first few months after installation the tannin naturally occurring in the timber may leach out and cause a brown staining on the bases. This may be removed with a light solution of household bleach and water.

Stainless Steel (polished stainless steel only)

Clean as required, but at least every three months, using a stainless steel polish and a lint free cloth. To remove ground in dirt, a stainless steel finishing pad may be required.

Polyester Powder Coated & Galvanised

For general cleaning using a damp cloth and warm soapy water only. Scourers and abrasive cleaners are NOT suitable for this type of finish and may damage it. Before using any cleaning agents to remove graffiti etc. try on a small, inconspicuous area first to avoid causing more unsightly damage.

Repairs

FSC Timber

For light damage, please see section on specific maintenance details above. For instances of heavy damage, the timber item should be replaced. Please order against the part number reference in the reordering section towards the end of this manual.

Stainless Steel

Light damage (surface scratches etc.) can be removed using an emery pad (240 grit) and freeing oil such as 'WD40'. Care should be taken to follow the direction of the brushing grain. It is recommended that a trial repair be carried out on an unimportant surface first. No corrosive cleaners or other abrasives should be used. Any contamination, particularly carbon steel scuffs from vehicles, should be quickly removed to avoid corrosion.

Polyester Powder Coated & Galvanised Surfaces

For light damage (scratches, chips etc.) repair using touch-up paint to match original colour (available from Factory Furniture Ltd). Paint application should be carried out in accordance with approved methods detailed by the paint manufacturer. Please note that it is advisable to use professional painters to achieve best results when touching up larger areas. Products for respraying larger areas are available from Factory Furniture Ltd.

Heavy Damage

In the event of serious damage to any component, replacements should be ordered from Factory Furniture Ltd. Should further assistance be required (or if the product needs to be disassembled for any reason), please contact Factory Furniture for detailed technical advice.

Reordering / Spares

Part #	Item Description
P1036 / 01	1 no. Tord bench slat set and ties (not incl. bases) - (2 no. outer slats and 3 no. inner slats total)
P1036 / 02	1 no. Tord seat slat set and ties (not incl. bases) - (2 no. outer slats and 5 no. inner slats total)
P1036 / 03	1 no. Tord back slat (not incl. frame) - (1 no. slat total)

Instructions For Reordering

If possible, please specify job name or number at the time of reordering to enable identification of details such as the original species of timber used, stainless steel finishes and polyester powder coat colours etc. In any event where either, additional orders are required, or spares and replacements are required please contact Factory Furniture Ltd. Using the part numbers given above as reference should help us to process your enquiry more efficiently.

Note - All fittings required to assemble ordered parts will automatically be included in the order.

AutoCAD Drawing List

FF1036 / 01	TORD BENCH	GENERAL ARRANGEMENT DRAWING
FF1036 / 02	TORD BENCH	PARTS DETAIL DRAWINGS
FF1036 / 03	TORD SEAT	GENERAL ARRANGEMENT DRAWING
FF1036 / 04	TORD SEAT	X-SECTION DRAWINGS
FF1036 / 05	TORD SEAT	PARTS DETAIL DRAWINGS (1)
FF1036 / 06	TORD SEAT	PARTS DETAIL DRAWINGS (2)

Contacts

Factory Furniture Ltd
5 Pioneer Road
Faringdon, Oxon
SN7 7BU UK

Tel +44 (0) 1367 242731
Email hello@factoryfurniture.co.uk
Web www.factoryfurniture.co.uk

Installation Instructions

ALL INSTALLATION WORKS TO BE CARRIED OUT BY COMPETENT PERSONNEL - INSTALL AS COMPLETE UNIT

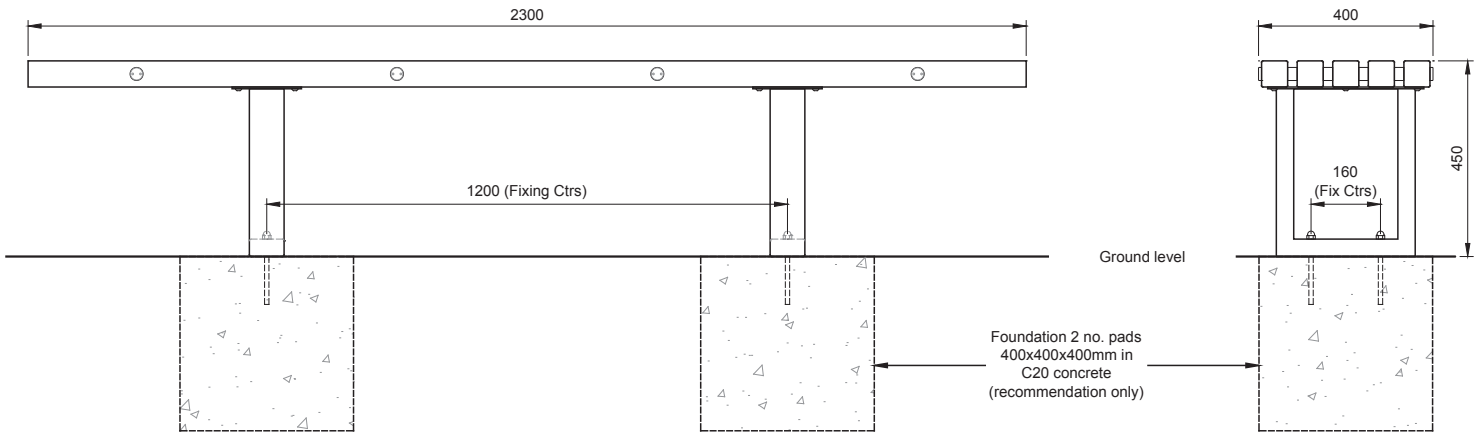

Tord Bench

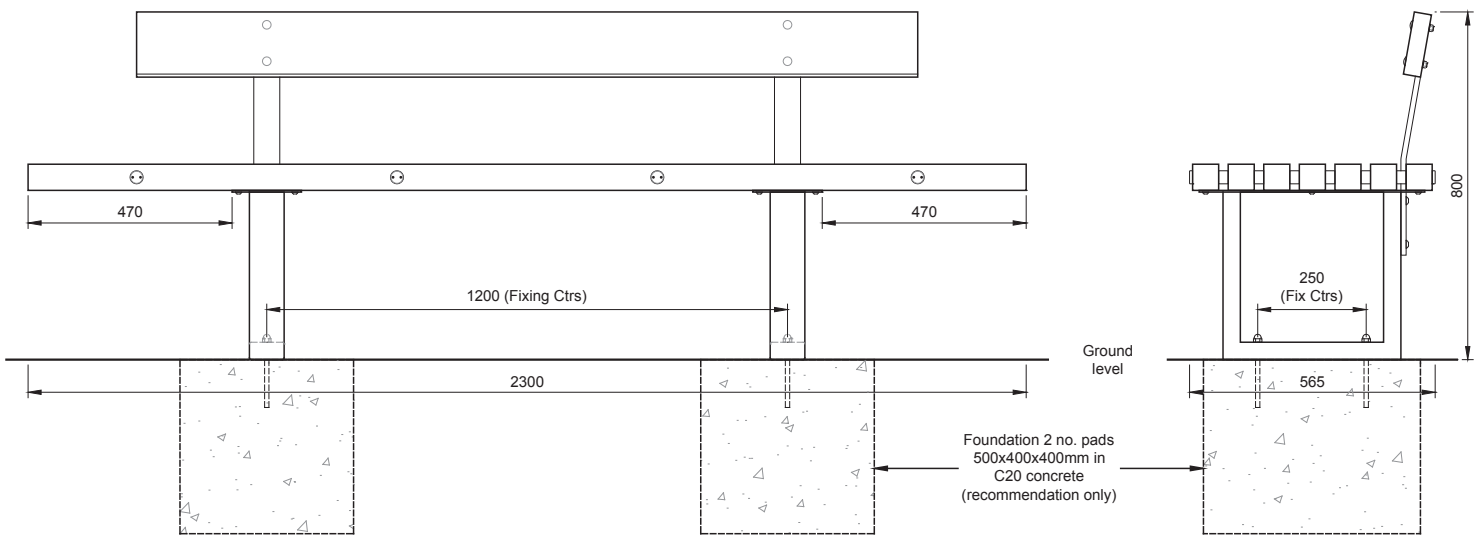

Tord Seat

Tord Bench / Seat

1. Install suitable foundation pads (see illustration) each with top face at ground level
2. If necessary attach backrest assembly (seat only) to seat using 4 no. M10x25mm button head bolts supplied
3. Position bench/seat in correct orientation with bases centrally on foundation pads, then mark hole positions through base frame.
4. Remove the bench/seat; drill holes $\text{\O}12\text{mm}$ x 125mm deep
5. Clear debris from holes.
6. Fill the holes to within approximately 35mm from the top with Hilti HY150 resin (or similar). Lift the bench/seat (with threaded anchor rods / capnuts in place) and carefully lower the anchors into the holes, leave for two hours before using.
7. Using a torque wrench, tighten nuts and washers over base frame to 30Nm to fasten down the bench/seat.
8. Check level

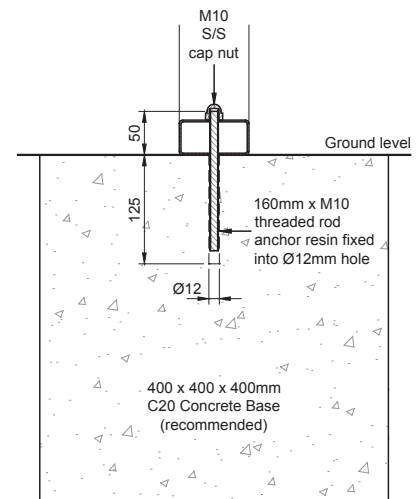

Base fix detail (showing bench)

IMPORTANT NOTE:

Ensure that stainless steel is protected during site cutting of stone – contamination from disc cutters will produce corrosion on stainless steel components.