

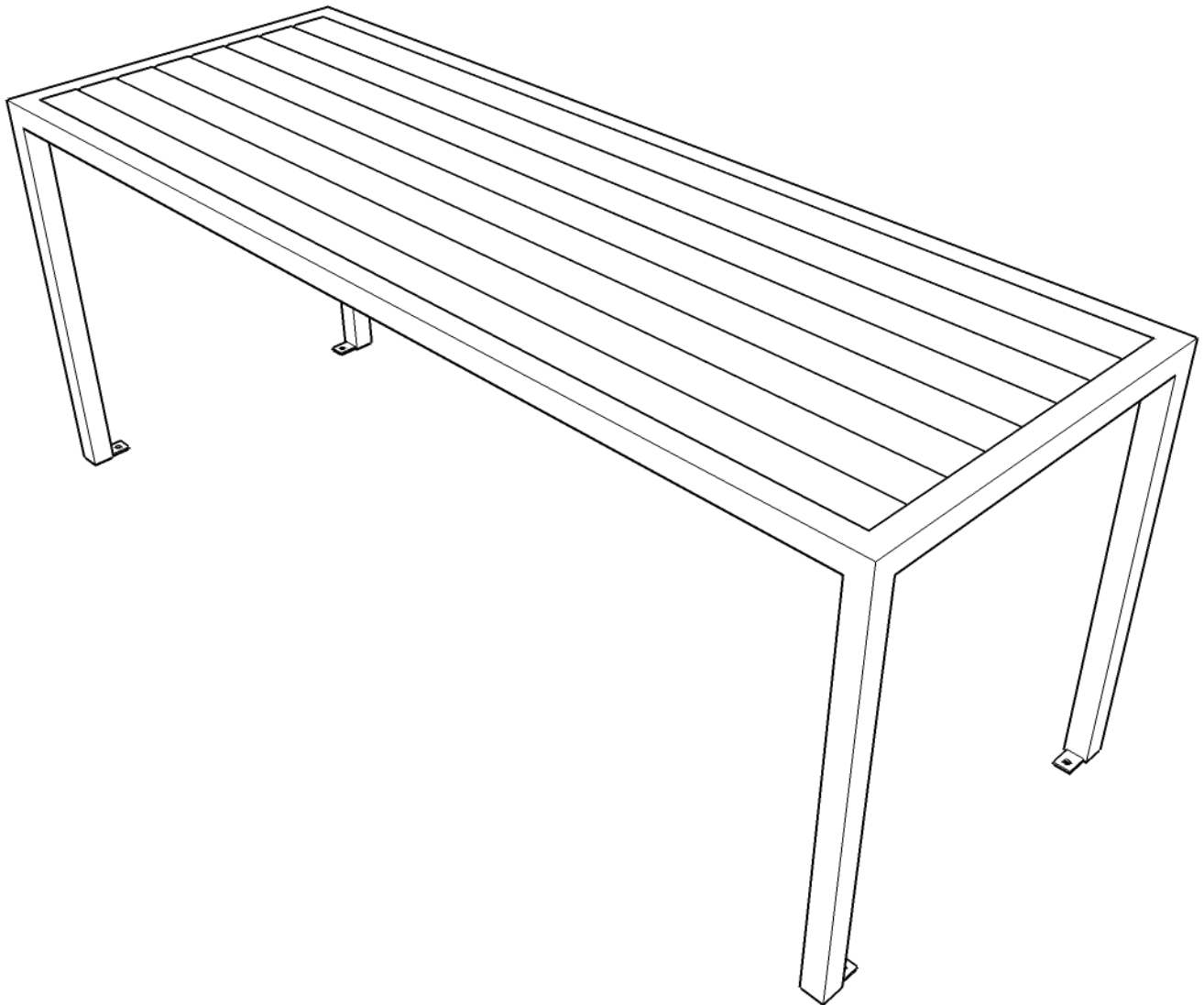

Factoryfurniture

UTIL table



Operation & Maintenance Manual

Introduction

Design

Design, shop drawings and development by Factory Furniture Ltd

Manufacture

Factory Furniture manufactured components. Products are assembled in Factory workshops, checked and dispatched ready for installation. Replacement products or components thereof should be ordered direct from Factory Furniture Ltd

Copyright

The design copyright for the product and drawing copyright remains the sole property of Factory Furniture Ltd

General Specifications

Table

Metric length 1900mm | width 700mm | height 750mm

Imperial length 6' 3" | width 2' 3½" | height 2' 5½"

Approx Weight 50kg

Fixing Centres 1860mm (6' 1") x 570mm (1' 10½")

Detailed Material & Finish Specifications

Table Slats

- Manufactured from FSC® certified tropical hardwood (*other FSC timber options available upon request*)
- Profiled and left untreated as standard (*oil or microporous woodstain treatment available on request*)
- Supported on frame and attached with 8 no. fixing points per slat



Frame

- Manufactured from stainless steel square section tubing with satin polished finish
- Anchored using 4 no. zinc-coated M10 x 75mm sleeve anchors per table (1 no. per leg)

General Maintenance *(Recommended Schedule & Guidelines)*

Daily/Weekly/Monthly *(or as adopted)*

Visual checks of table top and frame - check all items for superficial or physical damage.

Three Monthly

Clean all items as detailed below check all fixings are seated correctly; inspect timber for serious damage and splinters.

Six Monthly

Secure all fixings; full clean as detailed below; check that table is firmly secured to the ground

Specific Maintenance Details

FSC Timber

Clean with a stiff brush once per year, especially in more exposed locations, in order to prevent a verdigris type build up on the timber surface. Ideally this should be completed in early spring. During the cleaning stage, all exposed timber surfaces should be inspected for splits and splinters. Any splinters and graffiti should be removed and the surface sanded with 100 grit sandpaper in order to remove any uneven / sharp edges or surfaces.

During the first few months after installation the tannin naturally occurring in the timber may leach out and cause a brown staining on the bases. This may be removed with a light solution of household bleach and water.

Stainless Steel *(polished stainless steel only)*

Clean as required, but at least every three months, using a stainless steel polish and a lint free cloth. To remove ground in dirt, a stainless steel finishing pad may be required.

Repairs

FSC Timber

For light damage, please see section on specific maintenance details above. For instances of heavy damage, the timber item should be replaced. Please order against the part number reference in the reordering section towards the end of this manual.

Stainless Steel

Light damage (surface scratches etc.) can be removed using an emery pad (240 grit) and freeing oil such as 'WD40'. Care should be taken to follow the direction of the brushing grain. It is recommended that a trial repair be carried out on an unimportant surface first. No corrosive cleaners or other abrasives should be used. Any contamination, particularly carbon steel scuffs from vehicles, should be quickly removed to avoid corrosion.

Heavy Damage

In the event of serious damage to any component, replacements should be ordered from Factory Furniture Ltd. In this event (or if the product needs to be disassembled for any reason), please contact Factory Furniture for detailed technical advice.

Reordering / Spares

Part No.	Item Description
P2001 / 01	1 no. Util Table slat set (8 slats in total)

Instructions For Reordering

If possible, please specify job name or number at the time of reordering to enable identification of details such as the original species of timber used, stainless steel finishes and polyester powder coat colours etc. In any event where either, additional orders are required, or spares and replacements are required please contact Factory Furniture Ltd. Using the part numbers given above as reference should help us to process your enquiry more efficiently.

Note - All fittings required to assemble ordered parts will automatically be included in the order.

AutoCAD Drawing List

FF2001 / 01	UTIL TABLE	FABRICATION DRAWING
FF2001 / 02	UTIL TABLE	PARTS DETAILS DRAWING
FF2001 / 03	UTIL TABLE	SETTING OUT DRAWING

Contacts

Factory Furniture Ltd,
The Stableyard,
Coleshill,
Swindon.
Wiltshire SN6 7PT
U.K.

Tel +44 (0) 1793 763829
Fax +44 (0) 1793 861615
Email sales@factoryfurniture.co.uk
Web www.factoryfurniture.co.uk

Installation Instructions

ALL INSTALLATION WORKS TO BE CARRIED OUT BY COMPETENT PERSONNEL - INSTALL AS COMPLETE UNIT.

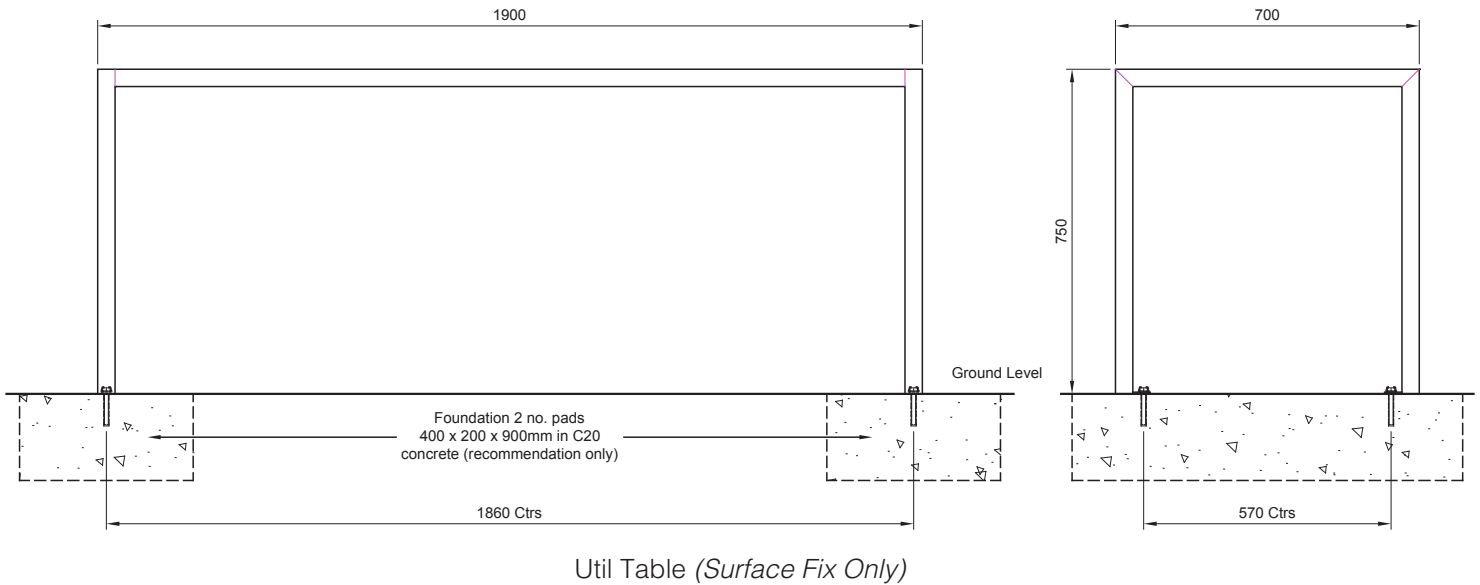

Util Table (surface fix only)

1. Install suitable foundation pads (see illustration) each with top face at ground level
2. Position table in correct orientation with bases centrally on foundation pads; then mark hole positions through fixing lugs.
3. Remove the table; drill holes $\text{\O}12\text{mm}$ x 75mm deep (or as bolt manufacturer's recommendations).
4. Clear debris from holes.
5. Reposition table unit and fix to foundation pads using 4 no. zinc-coated M10 x 75mm sleeve anchors tightened to 50Nm (or as per manufacturer's instruction). Ensure table remains level during fixing process. Finally hammer an anti-vandal armour ring over each bolt head to prevent tampering.
6. Check level & re-instate ground level if necessary (sub-surface fix).

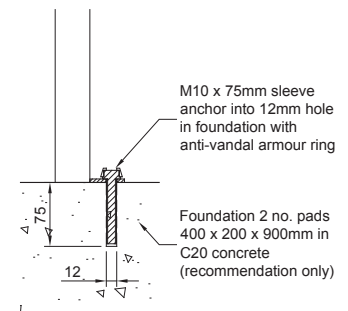

IMPORTANT NOTE:

Ensure that stainless steel is protected during site cutting of stone – contamination from disc cutters will produce corrosion on stainless steel components.