

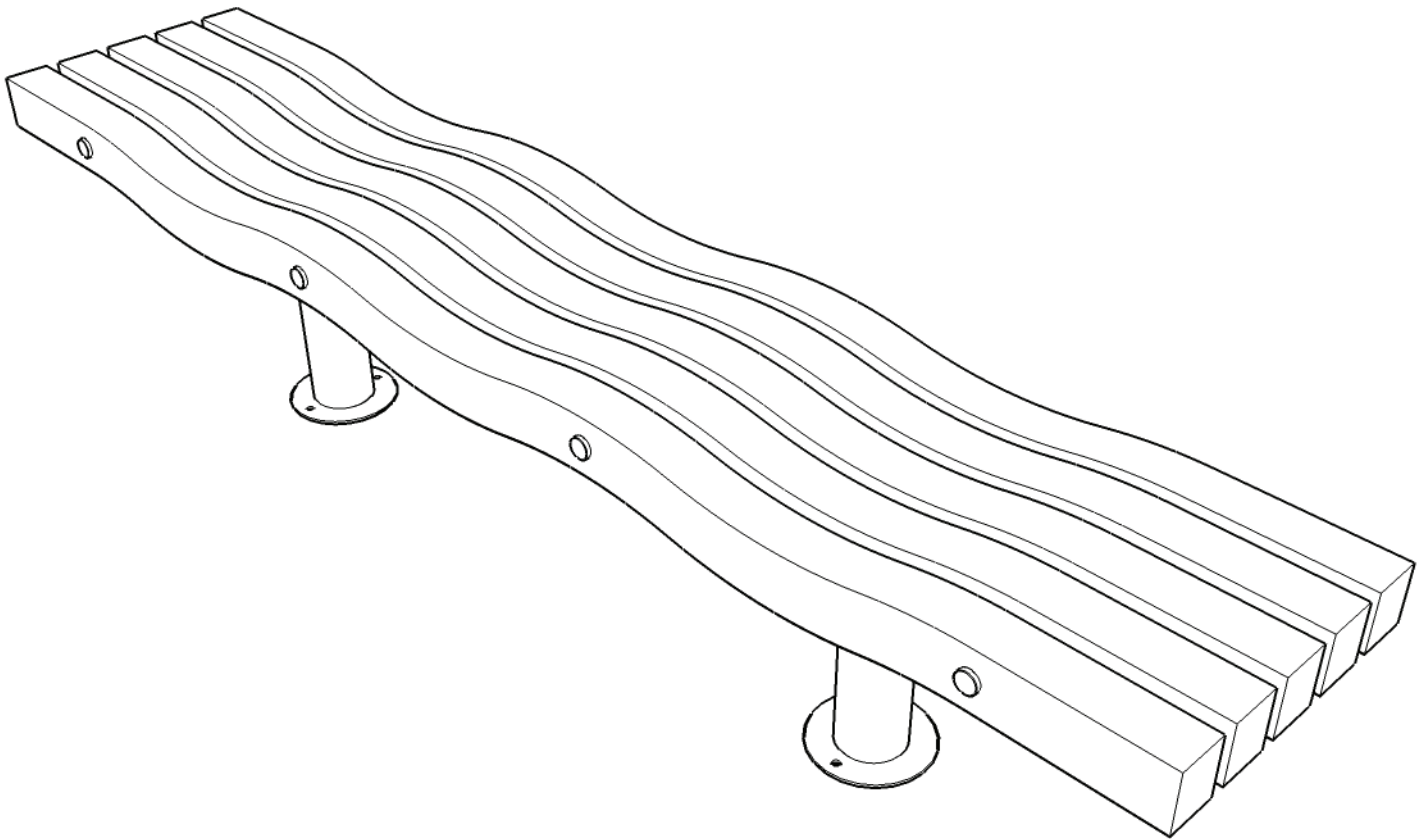

Factoryfurniture

5 SLAT SERPENTINE bench



Operation & Maintenance Manual

Introduction

Design

Design, shop drawings and development by Factory Furniture Ltd

Manufacture

Factory Furniture manufactured components. Products are assembled in Factory workshops, checked and dispatched ready for installation. Replacement products or components thereof should be ordered direct from Factory Furniture Ltd

Copyright

The design copyright for the product and drawing copyright remains the sole property of Factory Furniture Ltd

General Specifications

Bench

Metric length 2300mm | width 460mm | height 480mm* (460mm for ellipse and round bases)

Imperial length 7' 6½" | width 1' 6" | height 1' 7"

* Not inc. +100mm below gnd lvl - tube base sub-surface fix option

Approx weight 87kg (tubular) | 167kg (elliptical)

Fixing centres 1200mm (3' 11") (x 140mm (5½") for tubular base option only)

Detailed Material & Finish Specifications

Bench Slats

- Manufactured from FSC® certified tropical hardwood
- Profiled and left untreated as standard (oil or microporous woodstain treatment available on request)
- Spacers and end caps in aluminum (stainless steel available on request) concealing 4 no. zinc-coated mild steel threaded tie rods per bench top
- Supported on two bases (see options below) attached to bench top with 4 no. fixing points each



Bases - Tubular option

- Manufactured from stainless steel - satin polished or polyester powder coated (*powder coat colour grey as standard or to customer specification*)
- Anchored via 2 no. resin fixed M10 x 200mm threaded rods and cap nuts per base (surface fix) or 2 no. zinc-coated steel M10 x 75mm sleeve anchors per base (sub-surface fix)

Bases - Elliptical option

- Manufactured from bush hammered grey/white granite with 2 no. resin fixed stainless steel M8 studs per base for attachment to bench top.
- Anchored via a Ø20mm x 400mm resin fixed mild steel 'rebar'

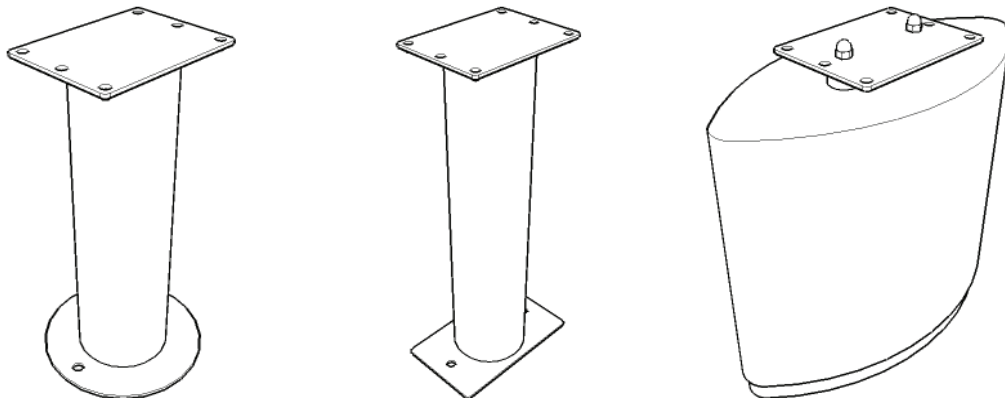

Base Options (from left to right) Tubular surface fix, Tubular sub-surface fix, Elliptical

General Maintenance *(Recommended Schedule & Guidelines)*

Daily/Weekly/Monthly *(or as adopted)*

Visual checks of seat top, back and bases - check all items for superficial or physical damage.

Three Monthly

Clean all items as detailed below check all fixings are seated correctly; inspect timber for serious damage and splinters.

Six Monthly

Secure all fixings; full clean as detailed below; check that seat/bench is firmly secured to the ground

Specific Maintenance Details

FSC Timber

Clean with a stiff brush once per year, especially in more exposed locations, in order to prevent a verdigris type build up on the timber surface. Ideally this should be completed in early spring. During the cleaning stage, all exposed timber surfaces should be inspected for splits and splinters. Any splinters and graffiti should be removed and the surface sanded with 100 grit sandpaper in order to remove any uneven / sharp edges or surfaces.

During the first few months after installation the tannin naturally occurring in the timber may leach out and cause a brown staining on the bases. This may be removed with a light solution of household bleach and water.

Stainless Steel *(polished stainless steel only)*

Clean as required, but at least every three months, using a stainless steel polish and a lint free cloth. To remove ground in dirt, a stainless steel finishing pad may be required.

Polyester Powder Coated

For general cleaning using a damp cloth and warm soapy water only. Scourers and abrasive cleaners are NOT suitable for this type of finish and may damage it. Before using any cleaning agents to remove graffiti etc. try on a small, inconspicuous area first to avoid causing more unsightly damage.

Granite / Concrete

Clean with a stiff brush once per year, especially in more exposed locations, in order to prevent a verdigris type build up on the surface. Ideally, this should be completed in early spring.

Repairs

FSC Timber

For light damage, please see section on specific maintenance details above. For instances of heavy damage, the timber item should be replaced. Please order against the part number reference in the reordering section towards the end of this manual.

Stainless Steel

Light damage (surface scratches etc.) can be removed using an emery pad (240 grit) and freeing oil such as 'WD40'. Care should be taken to follow the direction of the brushing grain. It is recommended that a trial repair be carried out on an unimportant surface first. No corrosive cleaners or other abrasives should be used. Any contamination, particularly carbon steel scuffs from vehicles, should be quickly removed to avoid corrosion.

Polyester Powder Coated Surfaces

For light damage (scratches, chips etc.) repair using touch-up paint to match original colour (available from Factory Furniture Ltd). Paint application should be carried out in accordance with approved methods detailed by the paint manufacturer. Please note that it is advisable to use professional painters to achieve best results when touching up larger areas. Products for respraying larger areas are available from Factory Furniture Ltd.

Heavy Damage

In the event of serious damage to any component, replacements should be ordered from Factory Furniture Ltd. In this event (or if the product needs to be disassembled for any reason), please contact Factory Furniture for detailed technical advice.

Reordering / Spares

Part #	Item Description
P1026 / 01	1 no. 5 slat serpentine bench unit (complete assembled unit - not including bases)
P1026 / 02	1 no. surface fix tubular base in stainless steel*
P1026 / 03	1 no. sub-surface fix tubular base in stainless steel*
P1026 / 04	1 no. elliptical base in bush hammered grey/white granite

*Please specify polished stainless or polyester coated at time of ordering

Instructions For Reordering

If possible, please specify job name or number at the time of reordering to enable identification of details such as the original species of timber used, stainless steel finishes and polyester powder coat colours etc. In any event where either, additional orders are required, or spares and replacements are required please contact Factory Furniture Ltd. Using the part numbers given above as reference should help us to process your enquiry more efficiently.

Note - All fittings required to assemble ordered parts will automatically be included in the order.

AutoCAD Drawing List

FF1026 / 01	5 SLAT SERPENTINE BENCH	FABRICATION DRAWINGS
FF1026 / 02	5 SLAT SERPENTINE BENCH	BASE FABRICATION DETAIL
FF1026 / 03	5 SLAT SERPENTINE BENCH	BASE SETTING OUT

Contacts

Factory Furniture Ltd
The Stableyard
Coleshill
Swindon
Wiltshire SN6 7PT
U.K.

Tel +44 (0) 1793 763829
Fax +44 (0) 1793 861615
Email sales@factoryfurniture.co.uk
Web www.factoryfurniture.co.uk

Installation Instructions

ALL INSTALLATION WORKS TO BE CARRIED OUT BY COMPETENT PERSONNEL - INSTALL AS COMPLETE UNIT.

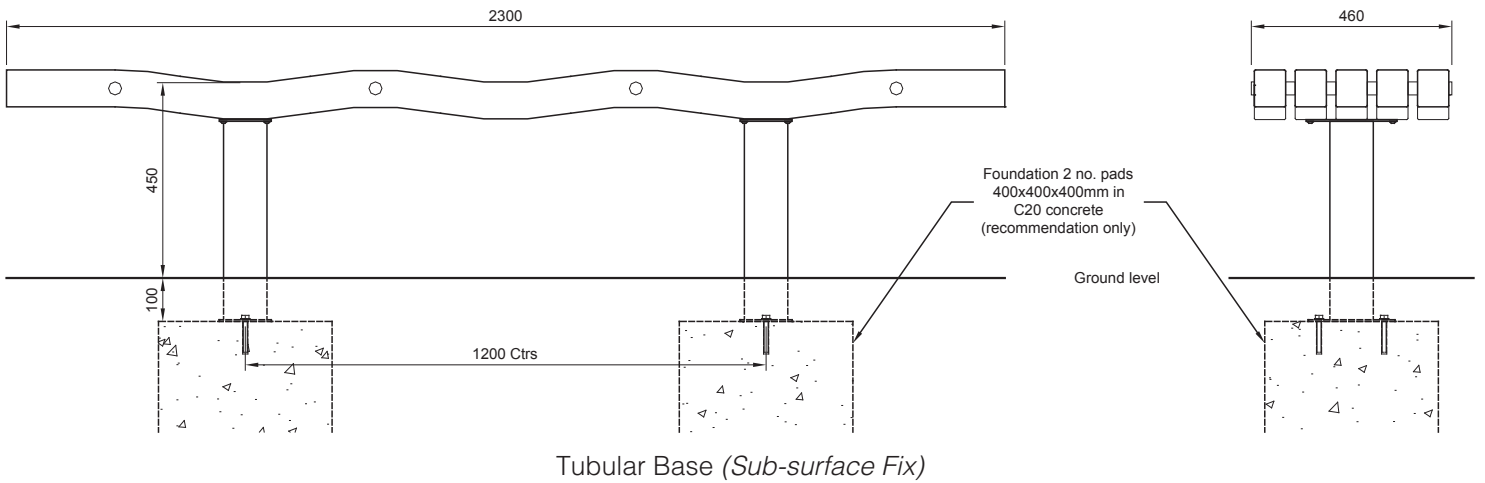
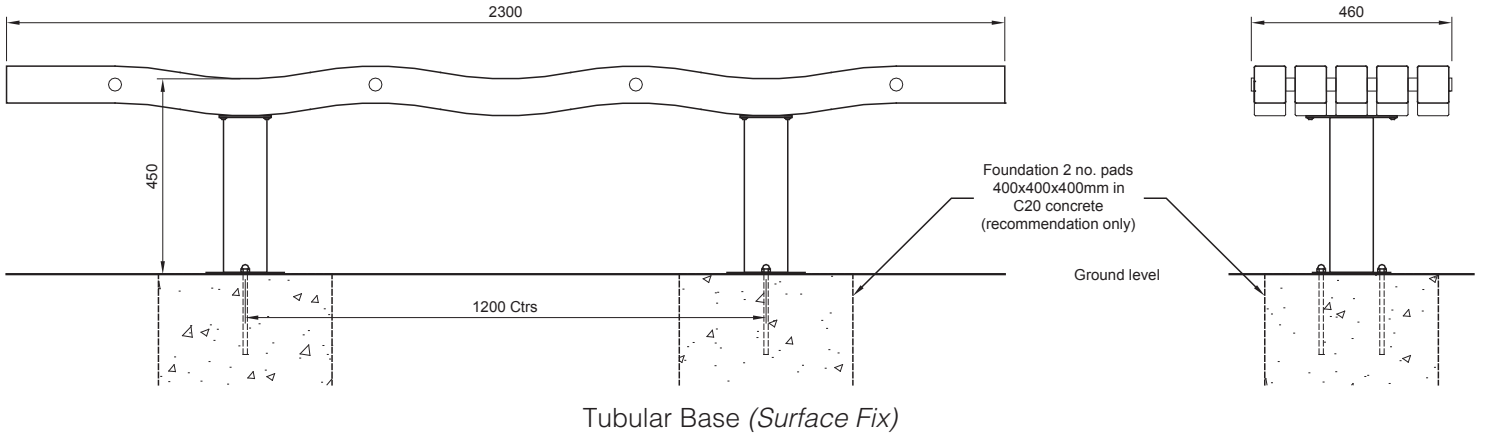

5 slat serpentine bench on tubular bases (*surface & sub-surface fix*)

1. Install suitable foundation pads (see illustration) each with top face at ground level or 100mm below finished ground level for sub-surface fix.

2. Unpack pair of bases and attach to the bench using the 8 no. M8 x 25mm button headed hex bolts and tighten to 14Nm.

3. Position bench in correct orientation with bases centrally on foundation pads; then mark hole positions through base plates.

4. Remove the bench; drill holes $\varnothing 14\text{mm}$ x 200mm deep (surface fix) or $\varnothing 12\text{mm}$ x 75mm deep or as manufacturer's recommendations (sub-surface fix).

5. Clear debris from holes.

6a. (*Surface fix*) Fill the holes to within approximately 35mm from the top with Hilti HY150 resin (or similar). Lift the bench (with threaded anchor rods/capnuts in place) and carefully lower the anchors into the holes, leave for two hours before using.

6b. Using a torque wrench, tighten nuts and washers over flange plates to 30Nm to fasten down the bench.

7. (*Sub-surface fix*) Reposition bench unit and fix to foundation pads using 4 no. zinc-coated M10 x 75mm sleeve anchors tightened to 50Nm (or as per manufacturer's instruction). Ensure bench remains level during fixing process.

8. Check level & re-instate ground level if necessary (sub-surface fix).

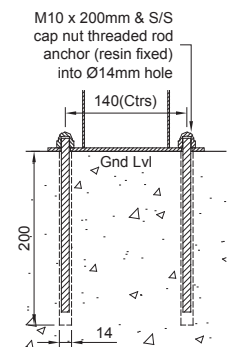

Surface Fix

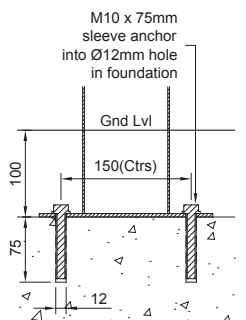

Sub-surface Fix

IMPORTANT NOTE:

Ensure that stainless steel is protected during site cutting of stone – contamination from disc cutters will produce corrosion on stainless steel components.

Installation Instructions

ALL INSTALLATION WORKS TO BE CARRIED OUT BY COMPETENT PERSONNEL - INSTALL AS COMPLETE UNIT.

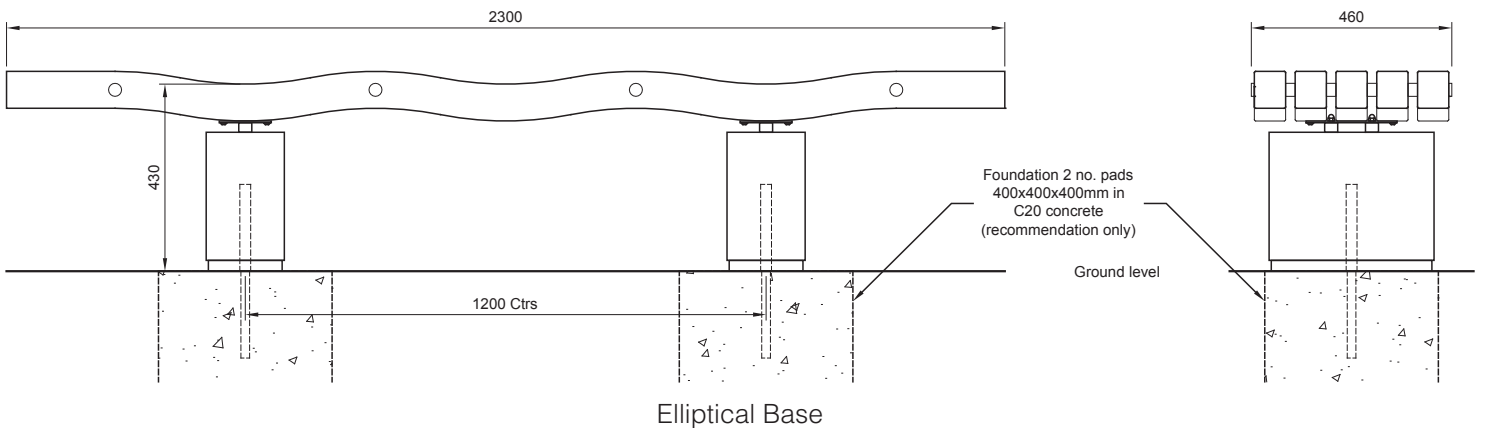

5 slat serpentine bench on elliptical bases

1. Install suitable foundation pads (see illustration) each with top face at ground level.
2. Unpack pair of bases and attach to the bench using the 8 no. M8 x 25mm button headed hex bolts and tighten to 14Nm.
3. Position bench in correct orientation with bases centrally on foundation pads;
4. Gently pivot the bench onto its front and mark the positions of the holes in the base onto the foundation pads.
5. With the bench still on its front, fill the central anchor hole in each base to within approximately 35mm from the top with Hilti HY150 resin (or similar) and insert $\text{\O}20\text{mm}$ x 400mm rebar anchor (supplied)
6. Bore $\text{\O}25\text{mm}$ x 230mm holes in the required positions in the foundation pads and remove any dust from the hole. Fill the holes to within approximately 35mm from the top with Hilti HY150 resin (or similar)
7. Lift the bench and carefully lower the anchors into the holes, leave for two hours before using.
8. If there are any lumps in the foundation's surface they will cause the bench to rock so it is recommended that if the foundation is a rough surface, resin is applied around each base before fixing and toweled clean when settled.

IMPORTANT NOTES:

Ensure that stainless steel is protected during site cutting of stone – contamination from disc cutters will produce corrosion on stainless steel components.

Granite must be treated with care, protect all edges when handling.