

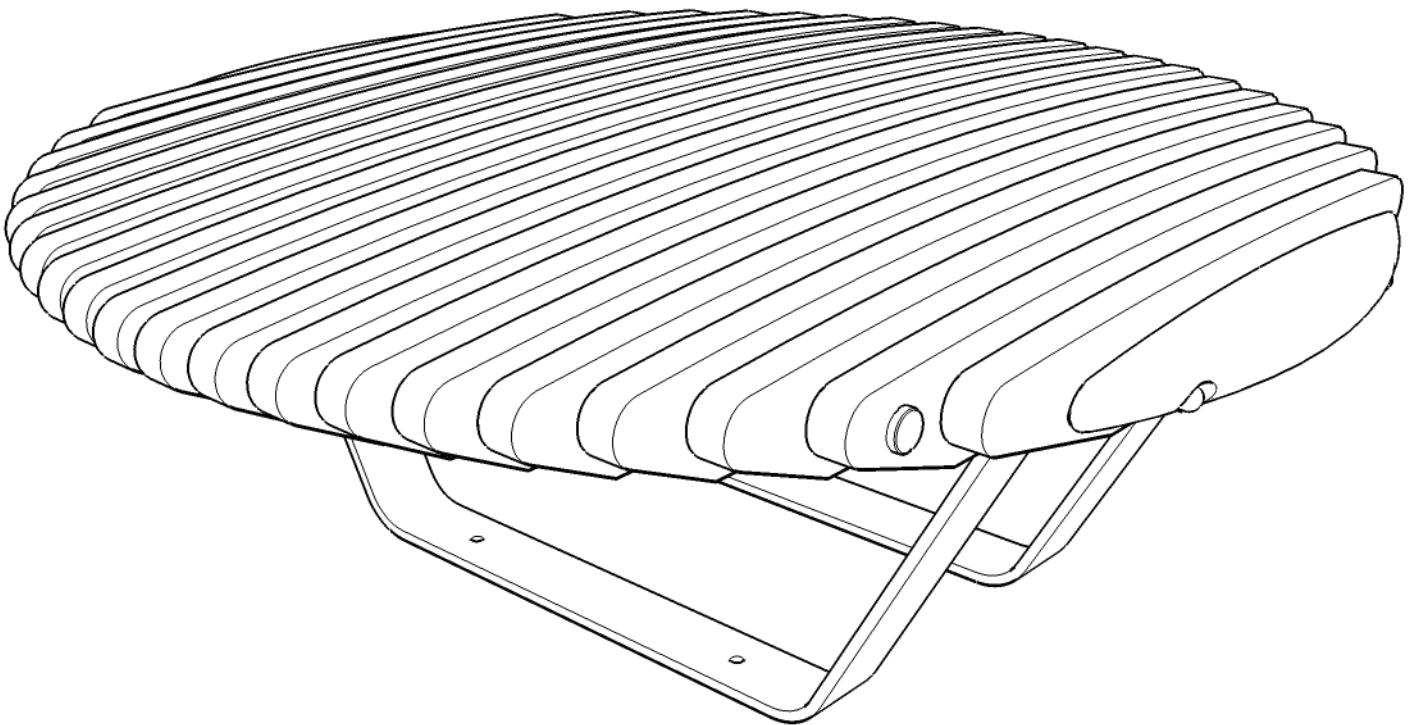

**Factoryfurniture**

## TONDO bench

---



# Operation & Maintenance Manual

---

# Introduction

## Design

Design, shop drawings and development by Factory Furniture Ltd

## Manufacture

Factory Furniture manufactured components. Products are assembled in Factory workshops, checked and dispatched ready for installation. Replacement products or components thereof should be ordered direct from Factory Furniture Ltd

## Copyright

The design copyright for the product and drawing copyright remains the sole property of Factory Furniture Ltd

# General Specifications

## Bench

*Metric* diameter 1200mm | height 450mm

*Imperial* diameter 3' 11" | height 1' 5½"

**Approx Weight** 103kg

**Fixing Centres** 310mm (12") x 340mm (1 1½")

# Detailed Material & Finish Specifications

## Bench Top

- Manufactured from FSC® certified tropical hardwood (*other FSC timber options available upon request*)
- Profiled and left untreated as standard (*oil or microporous woodstain treatment available on request*)
- Spacers and end caps in aluminum (*stainless steel available on request*) concealing 4 no. zinc-coated mild steel threaded tie rods per bench top
- Slats sandwiched between 2 no. polyester powder coated cast aluminium nose endcaps (*powder coat colour grey as standard or to customer specification*)
- Supported on two bases attached to bench top with 8 no. fixing points each



## Bases

- Manufactured from stainless steel with a satin polished finish
- Anchored using 2 no. resin fixed M10 x 200mm threaded rods and cap nuts per base (4 no. total per bench)

# General Maintenance *(Recommended Schedule & Guidelines)*

## Daily/Weekly/Monthly *(or as adopted)*

Visual checks of bench top and bases - check all items for superficial or physical damage.

## Three Monthly

Clean all items as detailed below check all fixings are seated correctly; inspect timber for serious damage and splinters.

## Six Monthly

Secure all fixings; full clean as detailed below; check that seat/bench is firmly secured to the ground

# Specific Maintenance Details

## FSC Timber

Clean with a stiff brush once per year, especially in more exposed locations, in order to prevent a verdigris type build up on the timber surface. Ideally this should be completed in early spring. During the cleaning stage, all exposed timber surfaces should be inspected for splits and splinters. Any splinters and graffiti should be removed and the surface sanded with 100 grit sandpaper in order to remove any uneven / sharp edges or surfaces.

*During the first few months after installation the tannin naturally occurring in the timber may leach out and cause a brown staining on the bases. This may be removed with a light solution of household bleach and water.*

## Stainless Steel *(polished stainless steel only)*

Clean as required, but at least every three months, using a stainless steel polish and a lint free cloth. To remove ground in dirt, a stainless steel finishing pad may be required.

## Polyester Powder Coated

For general cleaning using a damp cloth and warm soapy water only. Scourers and abrasive cleaners are NOT suitable for these types of finish and may damage them. Before using any cleaning agents to remove graffiti etc. try on a small, inconspicuous area first to avoid causing more unsightly damage.

---

# Repairs

## **FSC Timber**

For light damage, please see section on specific maintenance details above. For instances of heavy damage, the timber item should be replaced. Please order against the part number reference in the reordering section towards the end of this manual.

## **Stainless Steel**

Light damage (surface scratches etc.) can be removed using an emery pad (240 grit) and freeing oil such as 'WD40'. Care should be taken to follow the direction of the brushing grain. It is recommended that a trial repair be carried out on an unimportant surface first. No corrosive cleaners or other abrasives should be used. Any contamination, particularly carbon steel scuffs from vehicles, should be quickly removed to avoid corrosion.

## **Polyester Powder Coated Surfaces**

For light damage (scratches, chips etc.) repair using touch-up paint to match original colour (available from Factory Furniture Ltd). Paint application should be carried out in accordance with approved methods detailed by the paint manufacturer. Please note that it is advisable to use professional painters to achieve best results when touching up larger areas. Products for respraying larger areas are available from Factory Furniture Ltd.

## **Heavy Damage**

In the event of serious damage to any component, replacements should be ordered from Factory Furniture Ltd. In this event (or if the product needs to be disassembled for any reason), please contact Factory Furniture for detailed technical advice.

# Reordering / Spares

## **Part No.**

## **Item Description**

P1022 / 01	1 no. Tondo bench top assembly (complete assembled unit - not including bases)
P1022 / 02	1 no. Tondo nose endcap set (come as a pair)
P1022 / 03	1 no. Tondo base (come separately - 2 no. required per bench)

## **Instructions For Reordering**

If possible, please specify job name or number at the time of reordering to enable identification of details such as the original species of timber used, stainless steel finishes and polyester powder coat colours etc. In any event where either, additional orders are required, or spares and replacements are required please contact Factory Furniture Ltd. Using the part numbers given above as reference should help us to process your enquiry more efficiently.

Note - All fittings required to assemble ordered parts will automatically be included in the order.

# AutoCAD Drawing List

FF1022 / 01	TONDO BENCH	FABRICATION DRAWINGS
FF1022 / 02	TONDO BENCH	PARTS DETAIL DRAWING
FF1022 / 03	TONDO BENCH	SETTING OUT DRAWING

# Contacts

Factory Furniture Ltd,  
The Stableyard,  
Coleshill,  
Swindon.  
Wiltshire SN6 7PT  
U.K.

Tel +44 (0) 1793 763829  
Fax +44 (0) 1793 861615  
Email [sales@factoryfurniture.co.uk](mailto:sales@factoryfurniture.co.uk)  
Web [www.factoryfurniture.co.uk](http://www.factoryfurniture.co.uk)

# Installation Instructions

**ALL INSTALLATION WORKS TO BE CARRIED OUT BY COMPETENT PERSONNEL - INSTALL AS COMPLETE UNIT.**

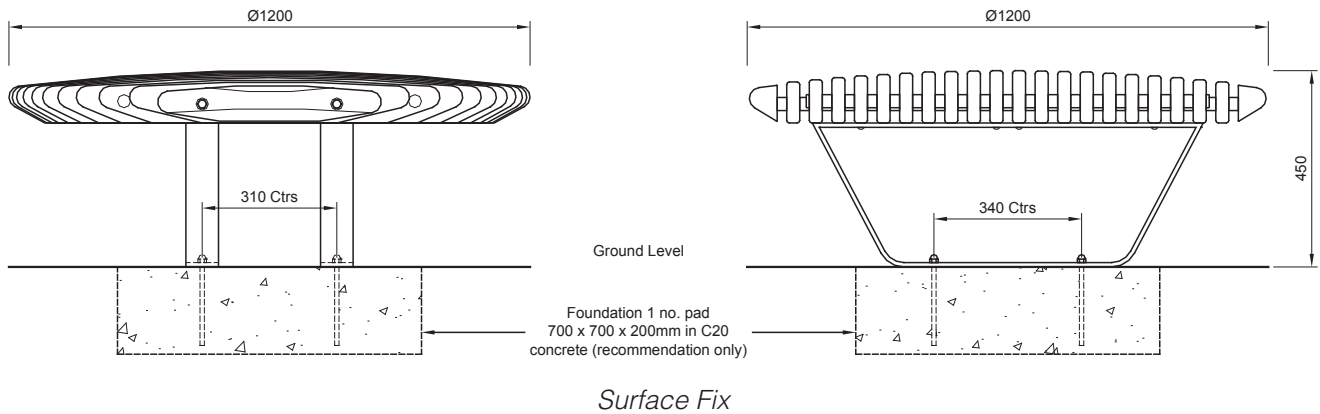

## **Tondo Bench** (surface fix only)

1. Install suitable foundation pads (see illustration) each with top face at ground level
2. Unpack pair of bases and attach to the bench using the 16 no. M8 x 30mm button headed hex bolts and tighten to 14Nm
3. Position bench in correct orientation with bases centrally on foundation pads, then mark hole positions through base plates.
4. Remove the bench; drill holes Ø12mm x 200mm deep. Clear debris from holes.
5. Fill the holes to within approximately 35mm from the top with Hilti HY150 resin (or similar). Lift the seat (with threaded anchor rods/capnuts in place) and carefully lower the anchors into the holes, leave for two hours before using.
6. Using a torque wrench, tighten nuts and washers over flange plates to 30Nm to fasten down the bench. Ensure bench remains level during fixing process.

## **IMPORTANT NOTE:**

Ensure that stainless steel is protected during site cutting of stone – contamination from disc cutters will produce corrosion on stainless steel components.

