

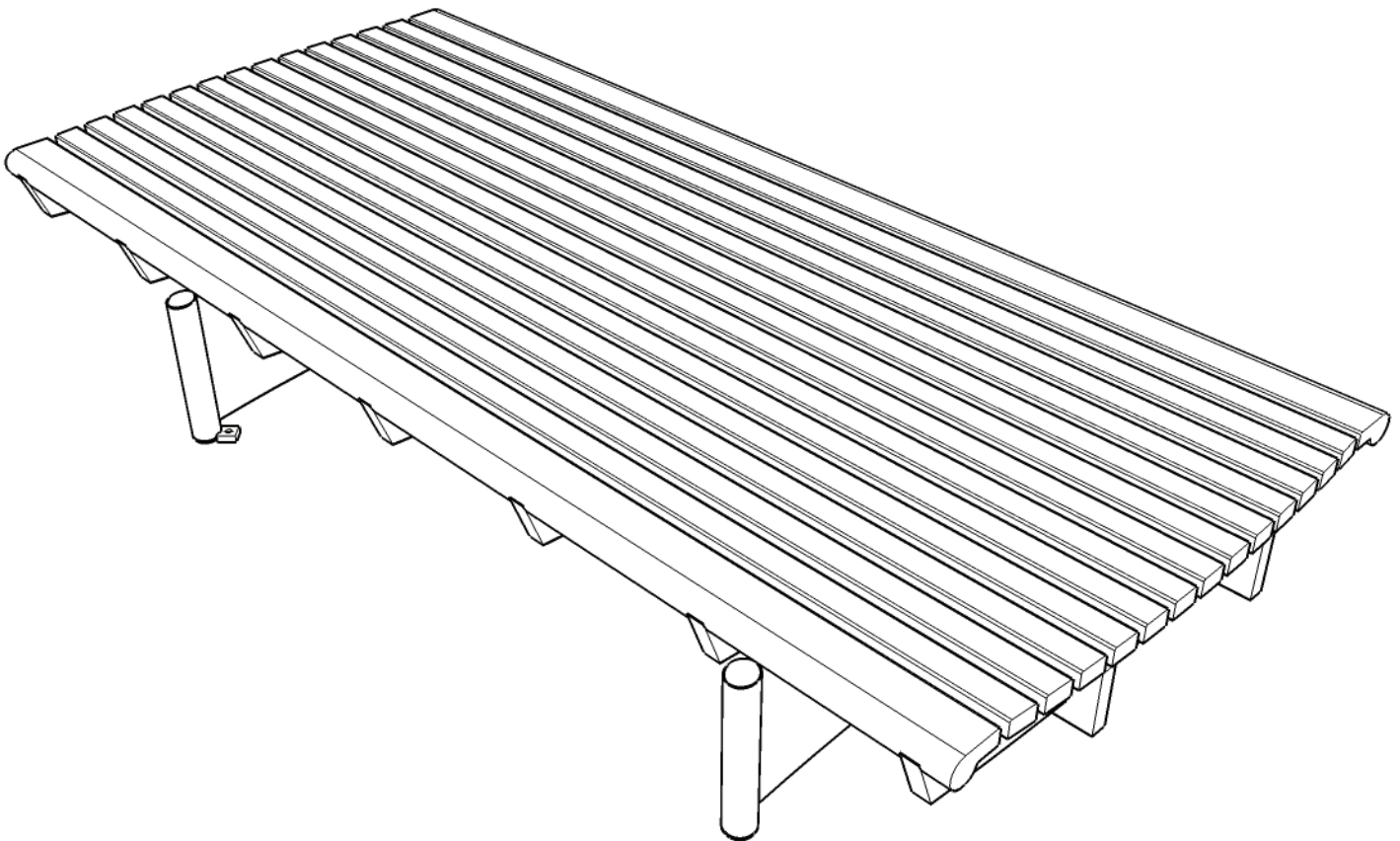

Factoryfurniture

DOUBLE SCROLL bench



Operation & Maintenance Manual

Introduction

Design

Design, shop drawings and development by Factory Furniture Ltd

Manufacture

Factory Furniture manufactured components. Products are assembled in Factory workshops, checked and dispatched ready for installation. Replacement products or components thereof should be ordered direct from Factory Furniture Ltd

Copyright

The design copyright for the product and drawing copyright remains the sole property of Factory Furniture Ltd

General Specifications

Bench

Metric length 2130mm | width 965mm | height 450mm

Imperial length 7' 0" | width 3' 2" | height 1' 5½"

Approx Weight 107kg

Fixing Centres 1265mm (4' 2") x 745mm (2' 5½")

Detailed Material & Finish Specifications

Seat Top *(slats & frame)*

- Manufactured from FSC® certified tropical hardwood or FSC certified oak *(other FSC timber options available upon request)*
- Profiled and left untreated as standard *(oil or microporous woodstain treatment available on request)*
- Supported on two bases attached to frame with 4 no. fixing points each



Bases

- Manufactured from mild steel - polyester powder coated finish *(powder coat colour grey as standard or to customer specification)*
- Anchored using 2 no. zinc-coated steel M10 x 75mm sleeve anchors per base - four anchors in total

General Maintenance *(Recommended Schedule & Guidelines)*

Daily/Weekly/Monthly *(or as adopted)*

Visual checks of seat top and bases - check all items for superficial or physical damage.

Three Monthly

Clean all items as detailed below check all fixings are seated correctly; inspect timber for serious damage and splinters.

Six Monthly

Secure all fixings; full clean as detailed below; check that bench is firmly secured to the ground

Specific Maintenance Details

FSC Timber

Clean with a stiff brush once per year, especially in more exposed locations, in order to prevent a verdigris type build up on the timber surface. Ideally this should be completed in early spring. During the cleaning stage, all exposed timber surfaces should be inspected for splits and splinters. Any splinters and graffiti should be removed and the surface sanded with 100 grit sandpaper in order to remove any uneven / sharp edges or surfaces.

During the first few months after installation the tannin naturally occurring in the timber may leach out and cause a brown staining on the bases. This may be removed with a light solution of household bleach and water.

Polyester Powder Coated

For general cleaning using a damp cloth and warm soapy water only. Scourers and abrasive cleaners are NOT suitable for this type of finish and may damage it. Before using any cleaning agents to remove graffiti etc. try on a small, inconspicuous area first to avoid causing more unsightly damage.

Repairs

FSC Timber

For light damage, please see section on specific maintenance details above. For instances of heavy damage, the timber item should be replaced. Please order against the part number reference in the reordering section towards the end of this manual.

Polyester Powder Coated Surfaces

For light damage (scratches, chips etc.) repair using touch-up paint to match original colour (available from Factory Furniture Ltd). Paint application should be carried out in accordance with approved methods detailed by the paint manufacturer. Please note that it is advisable to use professional painters to achieve best results when touching up larger areas. Products for respraying larger areas are available from Factory Furniture Ltd.

Heavy Damage

In the event of serious damage to any component, replacements should be ordered from Factory Furniture Ltd. In this event (or if the product needs to be disassembled for any reason), please contact Factory Furniture for detailed technical advice.

Reordering / Spares

Part No.	Item Description
P1019 / 01	1 no. Double scroll bench seat top (complete assembled unit - not including bases)
P1019 / 02	1 no. Double scroll bench surface fix base in mild steel

Instructions For Reordering

If possible, please specify job name or number at the time of reordering to enable identification of details such as the original species of timber used, stainless steel finishes and polyester powder coat colours etc. In any event where either, additional orders are required, or spares and replacements are required please contact Factory Furniture Ltd. Using the part numbers given above as reference should help us to process your enquiry more efficiently.

Note - All fittings required to assemble ordered parts will automatically be included in the order.

AutoCAD Drawing List

FF1019 / 01	DOUBLE SCROLL BENCH	FABRICATION DRAWING
FF1019 / 02	DOUBLE SCROLL BENCH	SEAT ASSEMBLY DETAILS DRAWING
FF1019 / 03	DOUBLE SCROLL BENCH	BASE ASSEMBLY DETAILS DRAWING
FF1019 / 04	DOUBLE SCROLL BENCH	SETTING OUT DRAWINGS

Contacts

Factory Furniture Ltd,
The Stableyard,
Coleshill,
Swindon.
Wiltshire SN6 7PT
U.K.

Tel +44 (0) 1793 763829
Fax +44 (0) 1793 861615
Email sales@factoryfurniture.co.uk
Web www.factoryfurniture.co.uk

Installation Instructions

ALL INSTALLATION WORKS TO BE CARRIED OUT BY COMPETENT PERSONNEL - INSTALL AS COMPLETE UNIT.

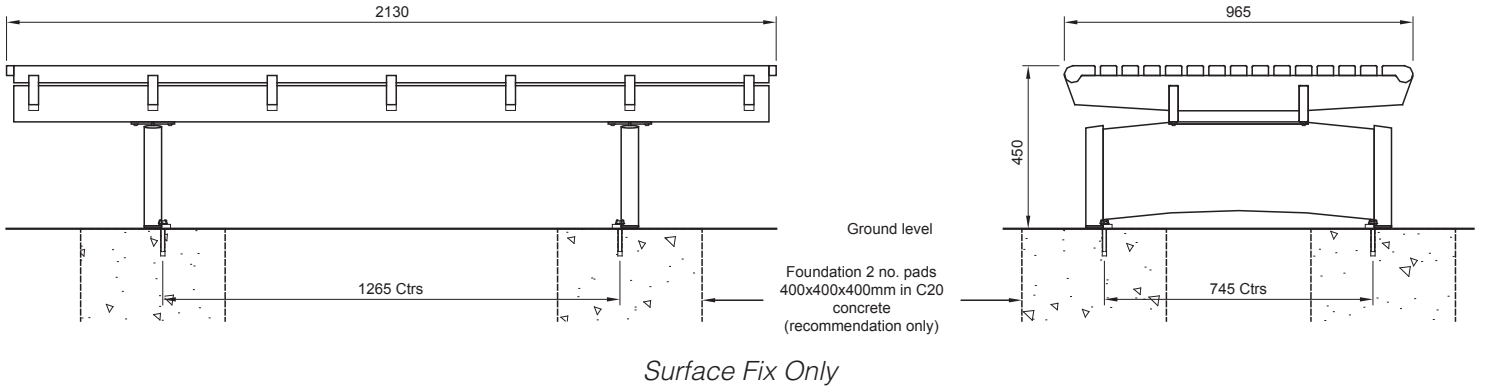

Double Scroll Bench (surface fix only)

1. Install suitable foundation pads (see illustration) each with top face at ground level
2. Unpack pair of bases and attach to the seat using the 8 no. M8 x 25mm button headed hex bolts and tighten to 14Nm
3. Position bench in correct orientation with bases centrally on foundation pads, then mark hole positions through fixing lugs.
4. Remove the bench; drill holes $\text{\O}12\text{mm}$ x 75mm deep or as manufacturer's instructions.
5. Clear debris from holes.
6. Reposition bench unit and fix to foundation pads using 4 no. zinc-coated M10 x 75mm sleeve anchors tightened to 50Nm (or as per manufacturer's instruction). Ensure bench remains level during fixing process.
7. Hammer an anti-vandal armour ring over each bolt head to prevent tampering.

