

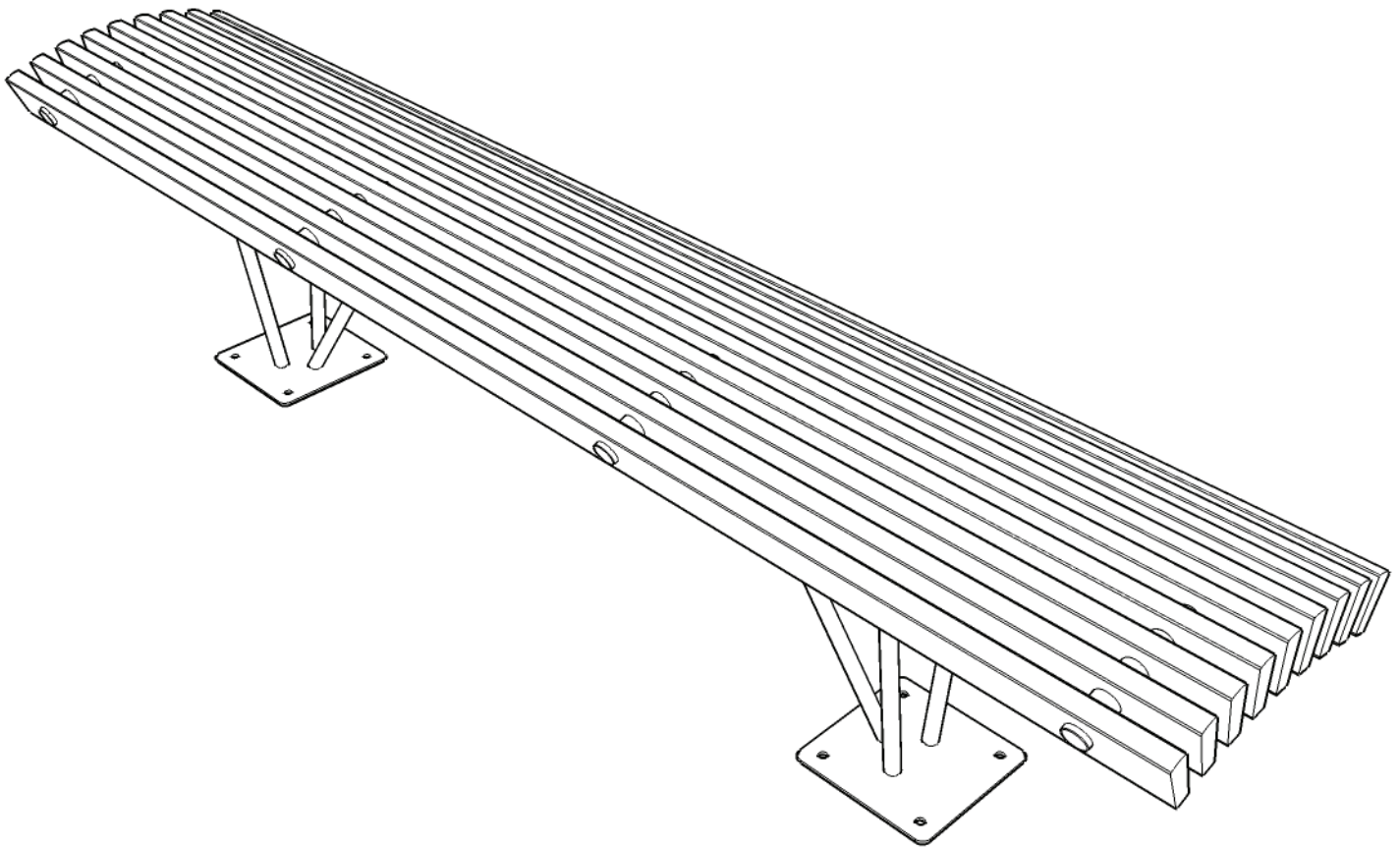

**Factoryfurniture**

## LOUVRE bench

---



# Operation & Maintenance Manual

---

# Introduction

## Design

Design, shop drawings and development by Factory Furniture Ltd

## Manufacture

Factory Furniture manufactured components. Products are assembled in Factory workshops, checked and dispatched ready for installation. Replacement products or components thereof should be ordered direct from Factory Furniture Ltd

## Copyright

The design copyright for the product and drawing copyright remains the sole property of Factory Furniture Ltd

# General Specifications

## Bench

*Metric* length 2100mm | width 390mm | height 450mm\*

*Imperial* length 6' 10½" | width 1' 3½" | height 1' 5½"

\* Not including +100mm below ground level for sub-surface fix option

**Approx weight** 40kg

**Fixing centres** 1270mm (4' 2") x 150mm (6")

# Detailed Material & Finish Specifications

## Seat top

- Slats are manufactured from FSC® certified tropical hardwood or FSC certified oak (*other FSC timber options available upon request*)

- Slats are profiled and left untreated as standard (*oil or microporous woodstain treatment available on request*)

- Spacers & end caps in aluminum (*stainless steel available on request*) concealing 4 no. zinc-coated mild steel threaded tie rods per seat top

- Supported on two feet attached via stainless steel plates with 4 no. fixing points each

## Feet

- Manufactured from stainless steel - satin polished. Comprising of 3 no. tubular uprights and upper & lower plates

- Anchored via 4 no. M10 x 75 zinc-coated steel sleeve anchors per base plate (8 no. total)

- Surface fix and sub-surface fix options available



# General Maintenance *(Recommended Schedule & Guidelines)*

## Daily/Weekly/Monthly *(or as adopted)*

Visual checks of seat top, back and bases - check all items for superficial or physical damage.

## Three Monthly

Clean all items as detailed below check all fixings are seated correctly; inspect timber for serious damage and splinters.

## Six Monthly

Secure all fixings; full clean as detailed below; check that seat/bench is firmly secured to the ground

# Specific Maintenance Details

## FSC Timber

Clean with a stiff brush once per year, especially in more exposed locations, in order to prevent a verdigris type build up on the timber surface. Ideally this should be completed in early spring. During the cleaning stage, all exposed timber surfaces should be inspected for splits and splinters. Any splinters and graffiti should be removed and the surface sanded with 100 grit sandpaper in order to remove any uneven / sharp edges or surfaces.

*During the first few months after installation the tannin naturally occurring in the timber may leach out and cause a brown staining on the bases. This may be removed with a light solution of household bleach and water.*

## Stainless Steel *(polished stainless steel only)*

Clean as required, but at least every three months, using a stainless steel polish and a lint free cloth. To remove ground in dirt, a stainless steel finishing pad may be required.

---

# Repairs

## **FSC Timber**

For light damage, please see section on specific maintenance details above. For instances of heavy damage, the timber item should be replaced. Please order against the part number reference in the reordering section towards the end of this manual.

## **Stainless Steel**

Light damage (surface scratches etc.) can be removed using an emery pad (240 grit) and freeing oil such as 'WD40'. Care should be taken to follow the direction of the brushing grain. It is recommended that a trial repair be carried out on an unimportant surface first. No corrosive cleaners or other abrasives should be used. Any contamination, particularly carbon steel scuffs from vehicles, should be quickly removed to avoid corrosion.

## **Heavy Damage**

In the event of serious damage to any component, replacements should be ordered from Factory Furniture Ltd. In this event (or if the product needs to be disassembled for any reason), please contact Factory Furniture for detailed technical advice.

# Reordering / Spares

<b>Part #</b>	<b>Item Description</b>
P1004 / 01	1 no. Louvre bench seat top unit (fully assembled)
P1004 / 02	1 no. Louvre bench foot unit (surface fix)
P1004 / 03	1 no. Louvre bench foot unit (sub-surface fix)

## **Instructions For Reordering**

If possible, please specify job name or number at the time of reordering to enable identification of details such as the original species of timber used, stainless steel finishes and polyester powder coat colours etc. In any event where either, additional orders are required, or spares and replacements are required please contact Factory Furniture Ltd. Using the part numbers given above as reference should help us to process your enquiry more efficiently.

Note - All fittings required to assemble ordered parts will automatically be included in the order.

# AutoCAD Drawing List

FF1004 / 01	LOUVRE BENCH	FABRICATION DRAWING
FF1004 / 02	LOUVRE BENCH	FOOT ASSEMBLY FABRICATION DRAWING
FF1004 / 03	LOUVRE BENCH	SETTING OUT DRAWING

# Contacts

Factory Furniture Ltd  
The Stableyard  
Coleshill  
Swindon  
Wiltshire SN6 7PT  
U.K.

Tel +44 (0) 1793 763829  
Fax +44 (0) 1793 861615  
Email [sales@factoryfurniture.co.uk](mailto:sales@factoryfurniture.co.uk)  
Web [www.factoryfurniture.co.uk](http://www.factoryfurniture.co.uk)

# Installation Instructions

**ALL INSTALLATION WORKS TO BE CARRIED OUT BY COMPETENT PERSONNEL - INSTALL AS COMPLETE UNIT.**

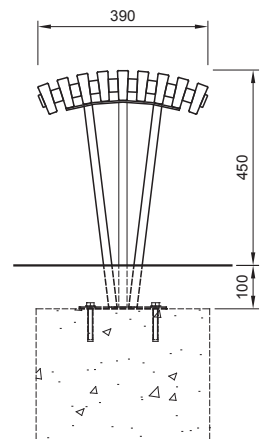
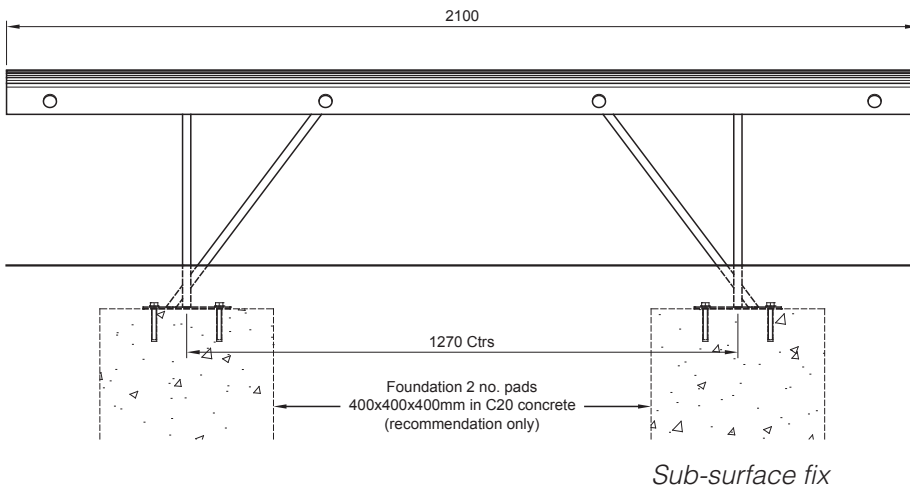
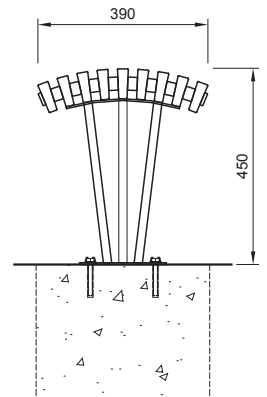
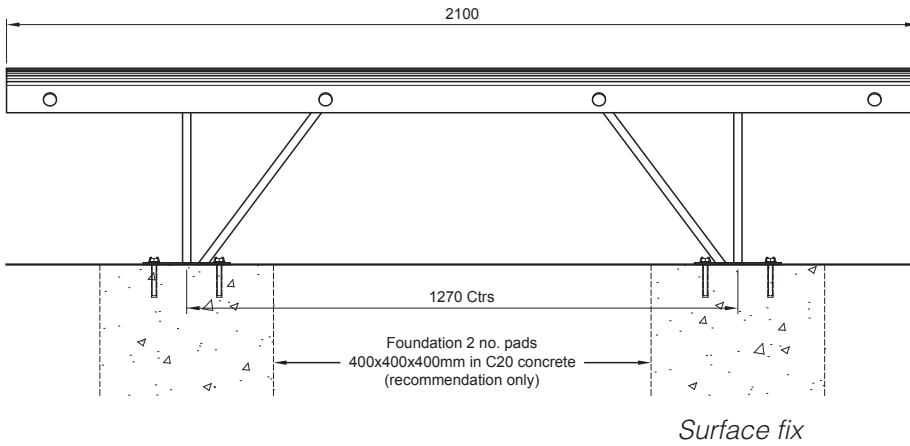

## **LOUVRE bench** (surface & sub-surface fix)

1. Install suitable foundation pads (see illustration) each with top face at ground level or 100mm below finished ground level for sub-surface fix
2. Position bench in correct orientation with bases centrally on foundation pads; then mark hole positions through base plates.
3. Remove the bench; drill holes  $\text{Ø}12\text{mm}$  x 75mm deep or as manufacturer's recommendations (sub-surface fix).
4. Clear debris from holes.
5. Reposition bench unit and fix to foundation pads using 4 no. zinc-coated M10 x 75mm sleeve anchors tightened to 50Nm (or as per manufacturer's instruction). Ensure bench remains level during fixing process. For surface fix, hammer an anti-vandal armour ring over each bolt head to prevent tampering.
6. Check level & re-instate ground level if necessary (sub-surface fix).

## **IMPORTANT NOTE:**

Ensure that stainless steel is protected during site cutting of stone – contamination from disc cutters will produce corrosion on stainless steel components.

